

1 Cooling circuit
 in#1 out T1-T6
 in#2 out T1-T6
 1xM5-out nearby (T1)

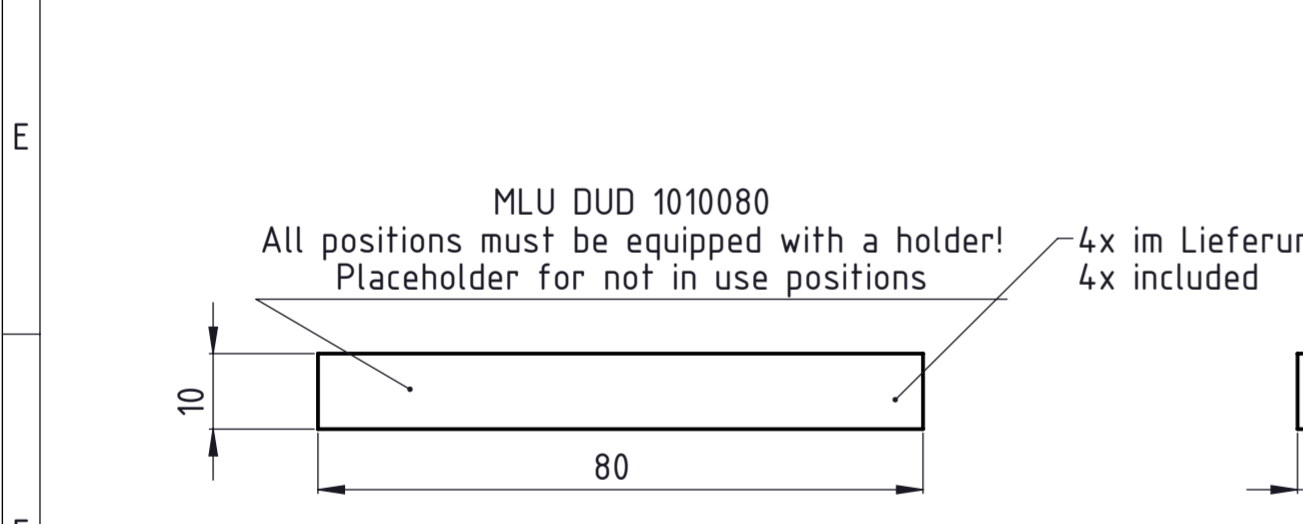

*Original Spannkeile können verwendet werden
 Les cales de serrage d'origine peuvent être utilisées
 Original clamping wedges can be used*

Lx=
 Vorstandlänge des Werkzeuges für optimale Kühlung
 Longueur d'outil pour un refroidissement optimal
 Tool length for optimal cooling

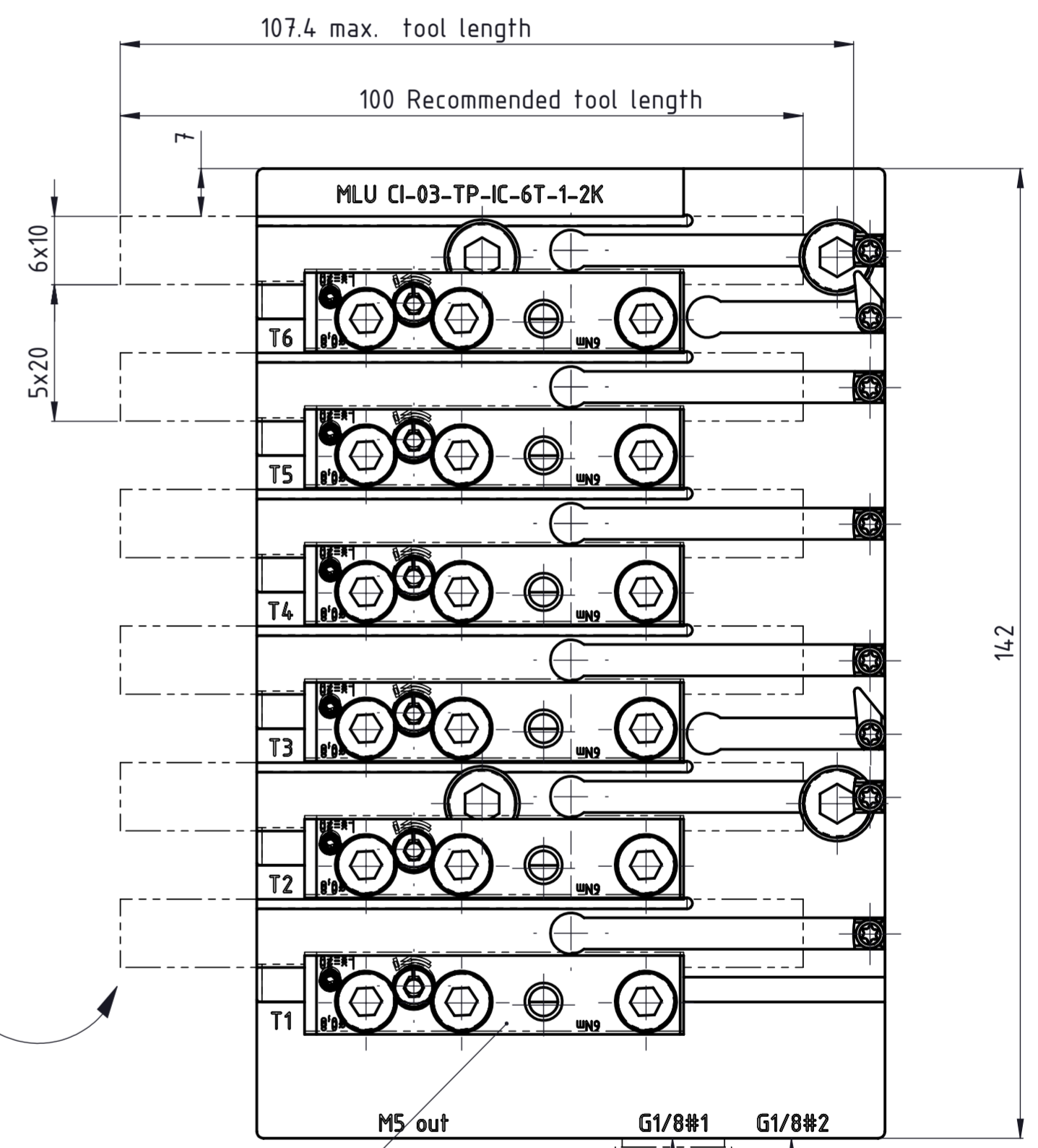
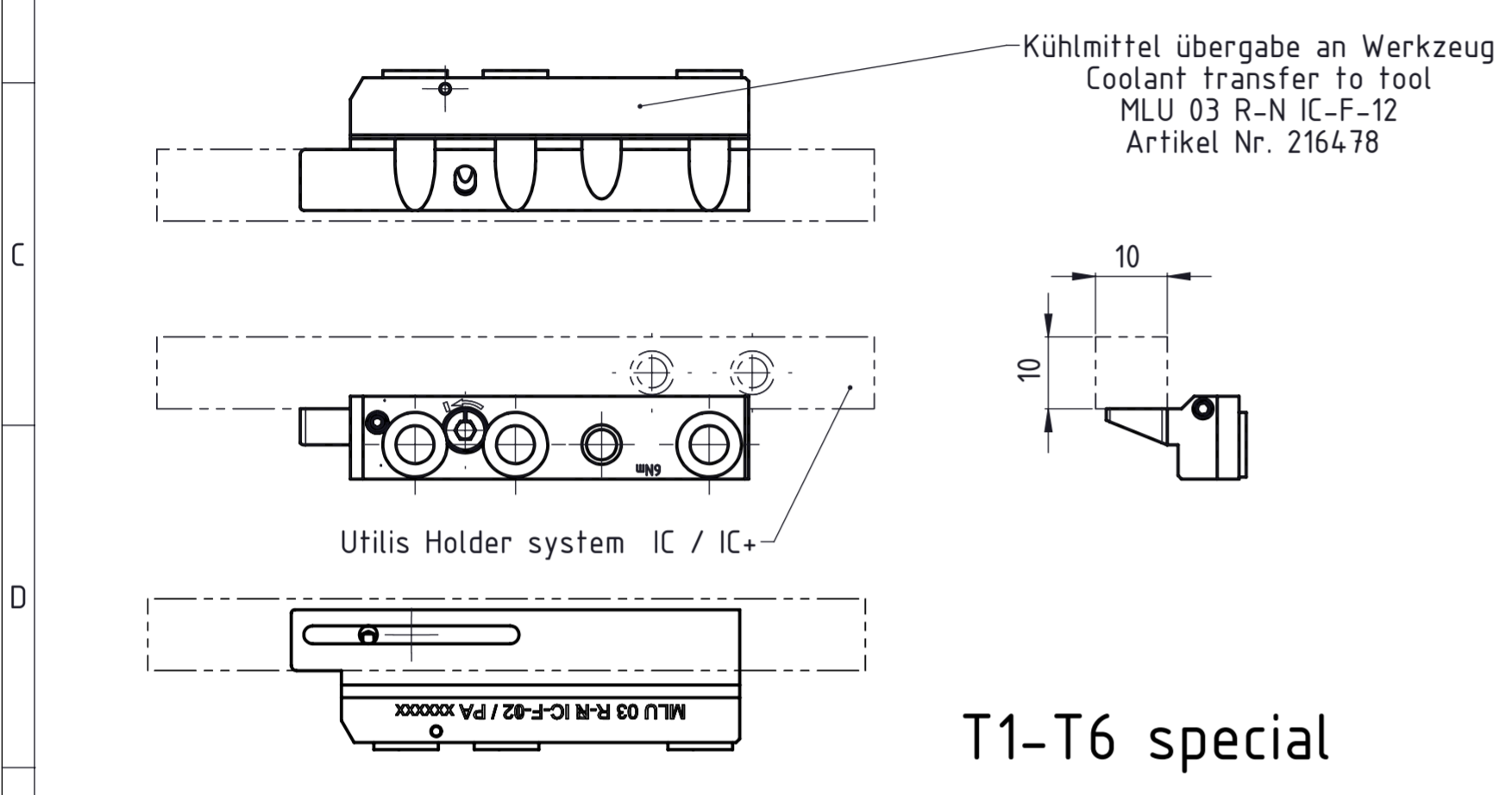
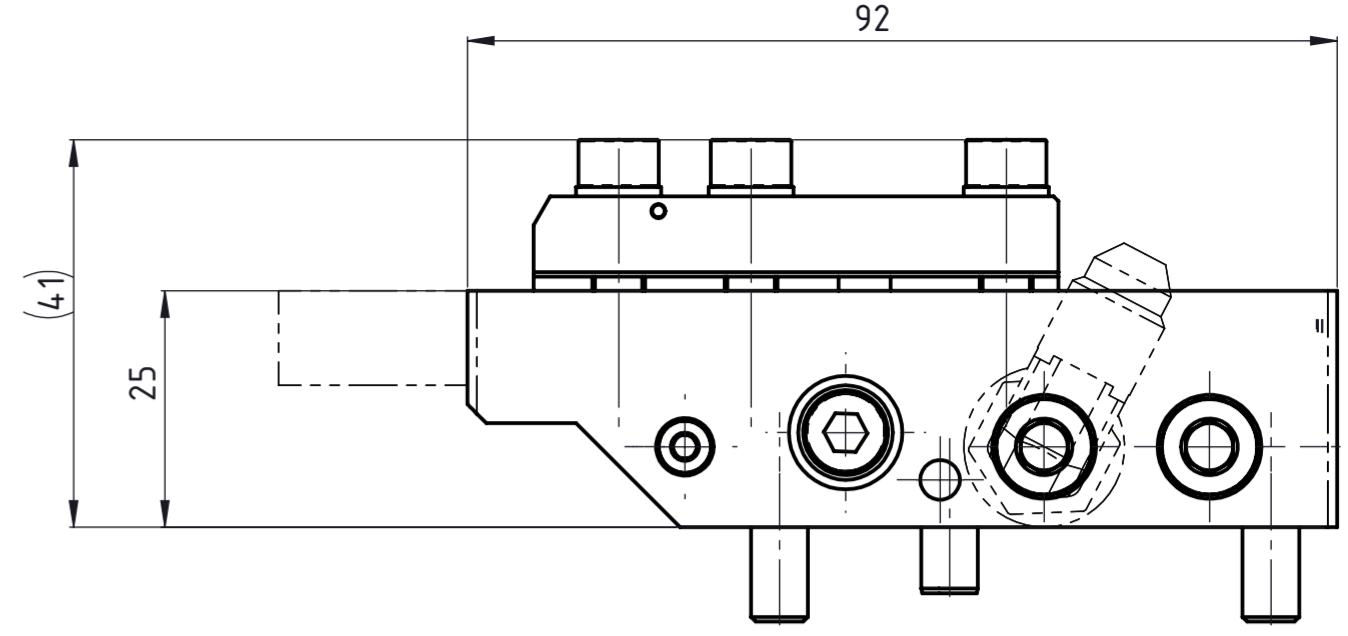
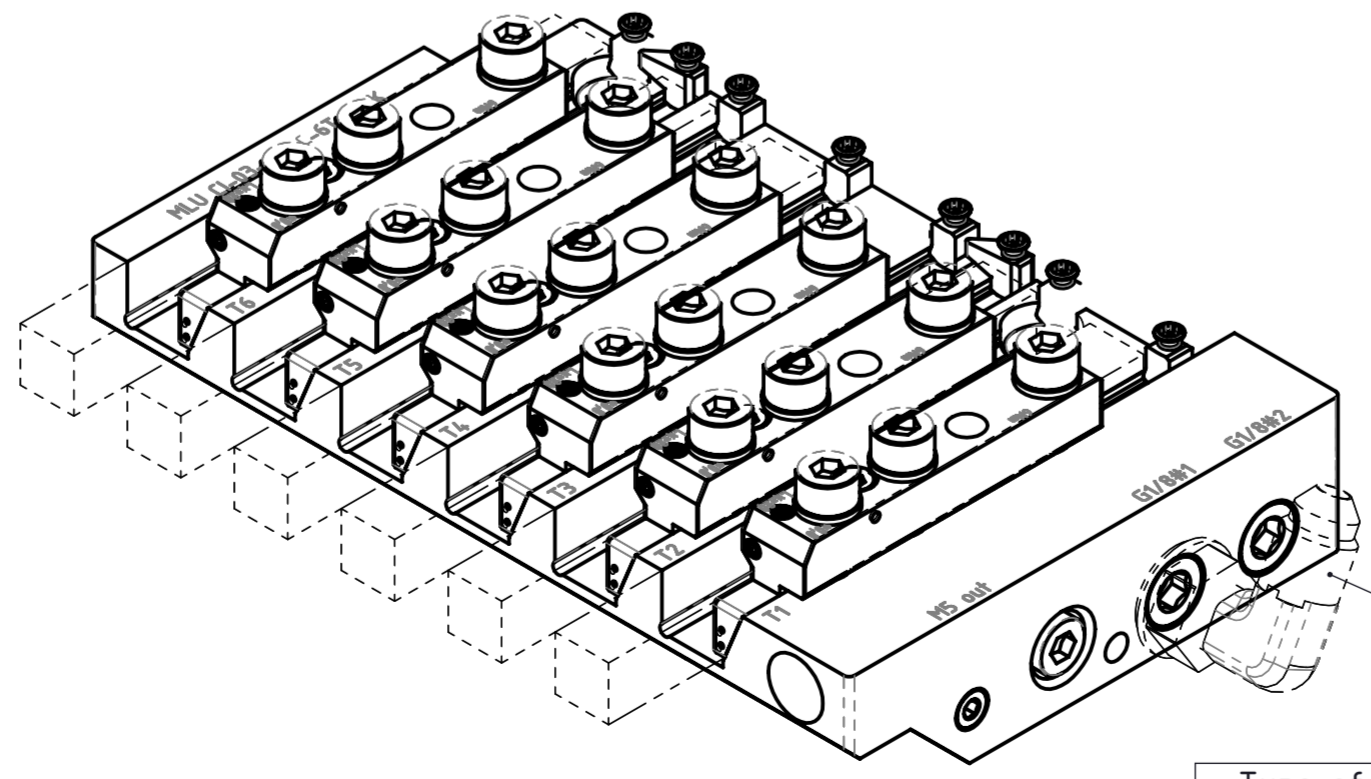

T1-T6
 rechts, droite, right
 MLU 03 R-R IC-F-02
 Artikel Nr. 194304
 G1/8 - 7/16-20 UNF 90° einstellbar
 nicht im Lieferumfang enthalten
 not included

Type of machine	Plate ref.	docking systems and sizes (DS)	Tool Size
Citizen L12 VII 7	GTF7010(10x10x) / 7010L 3/8"x3/8"	2xG1/8"	T1 -T6 10x10

Beschreibung	Artikel Bezeichnung	Zeichnungsnummer	UTILIS	Format	Index
multidec-LUB Werkzeugplatte komplett	MLU CI-03-TPC-IC-6T	MLU-103-1-2	UTILIS Tooling for High Technology	A2	D