

A

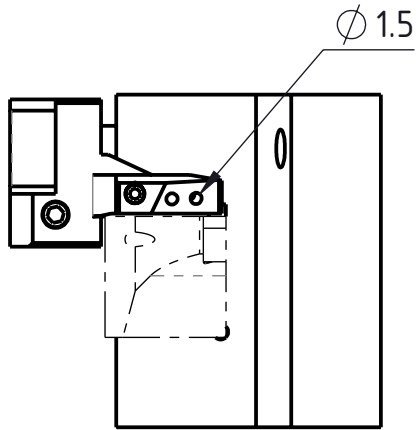

A

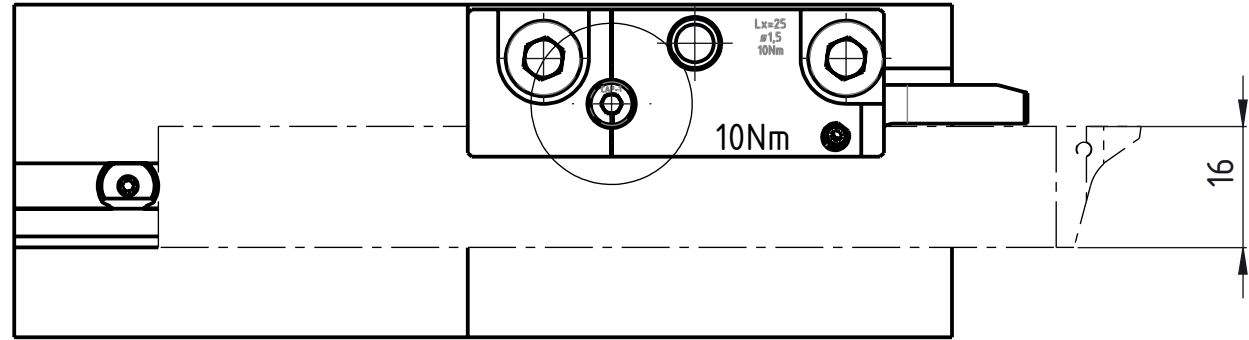

B

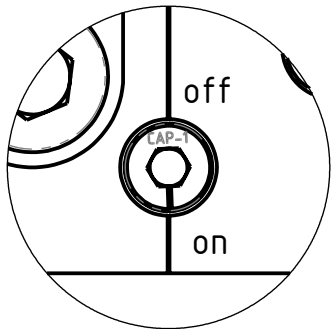

A (2 : 1)

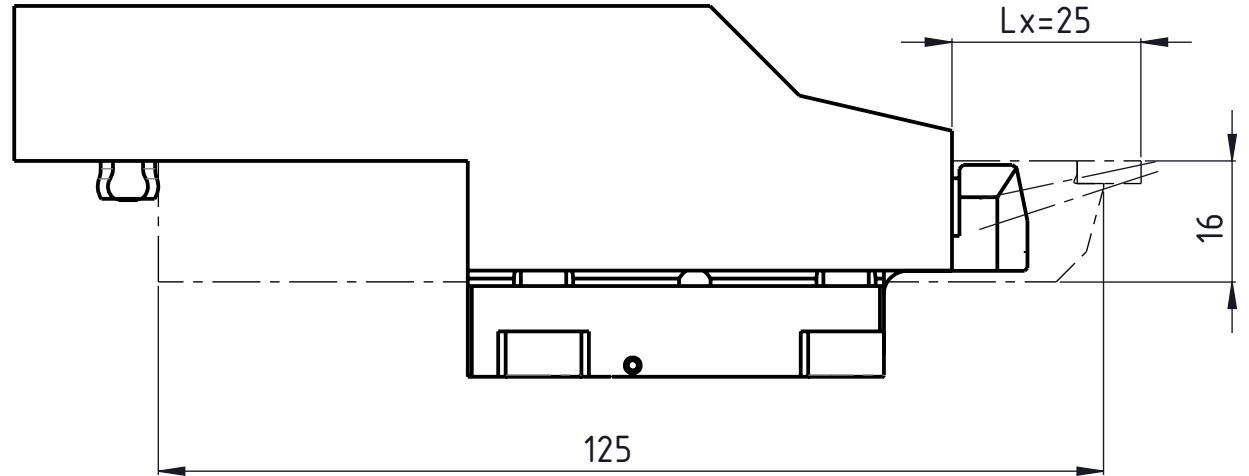

D

Type of machine	Tools size
Tornos GT26	16x16
Beschreibung	
multidec Lub Keil	

Lx=  
 Vorstandlänge des Werkzeuges für optimale Kühlung  
 Longueur d'outil pour un refroidissement optimal  
 Tool length for optimal cooling

Artikel Bezeichnung  
 MLU 01 R-R IC-F-10

Zeichnungsnummer  
 MLU-110-03-01

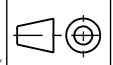

Index  
 A