

2 Kühleingänge 2 Kühlkreise  
 in-1 für T1-T3  
 in-2 für T4-T7

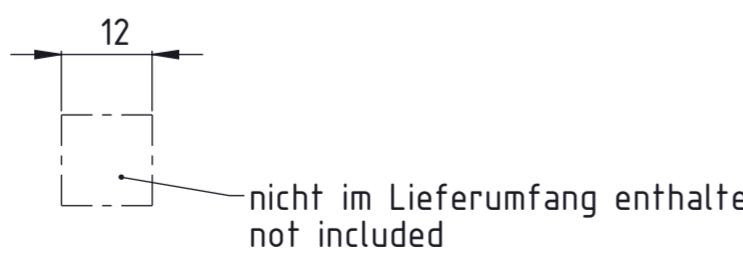
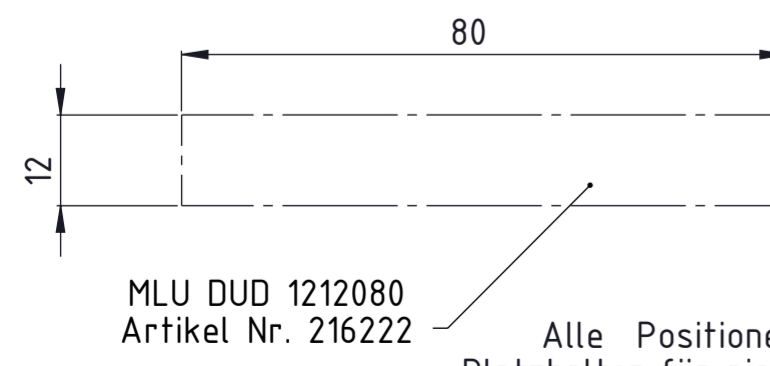
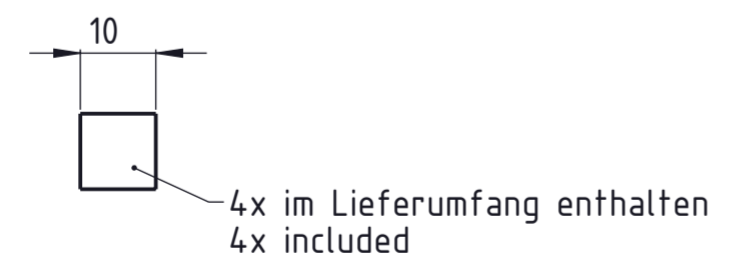
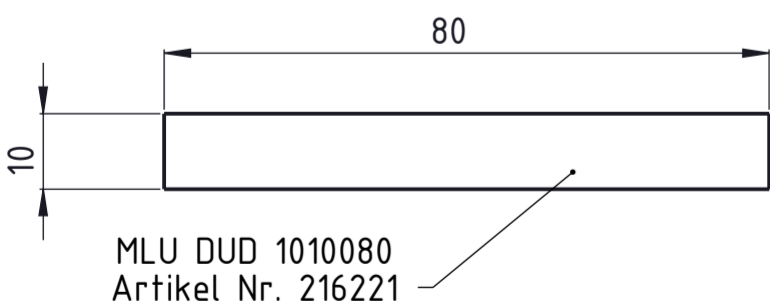
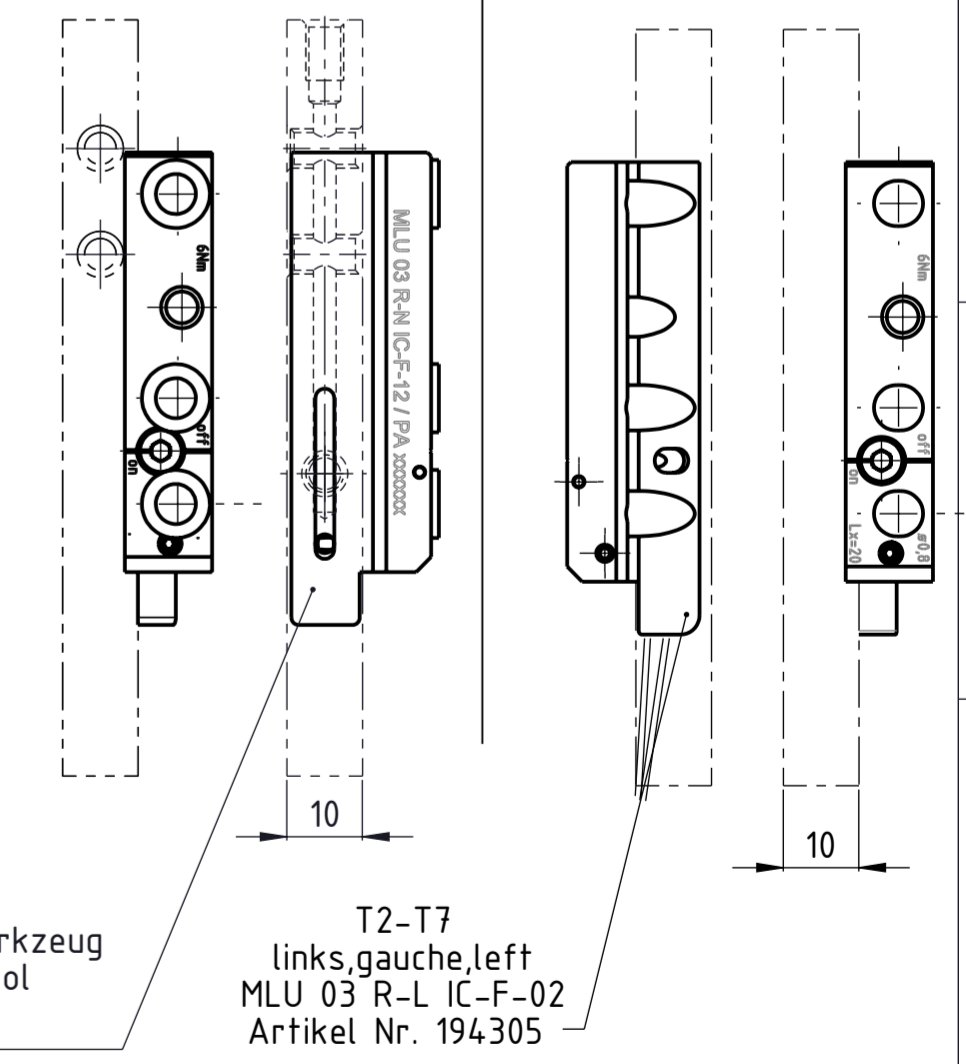
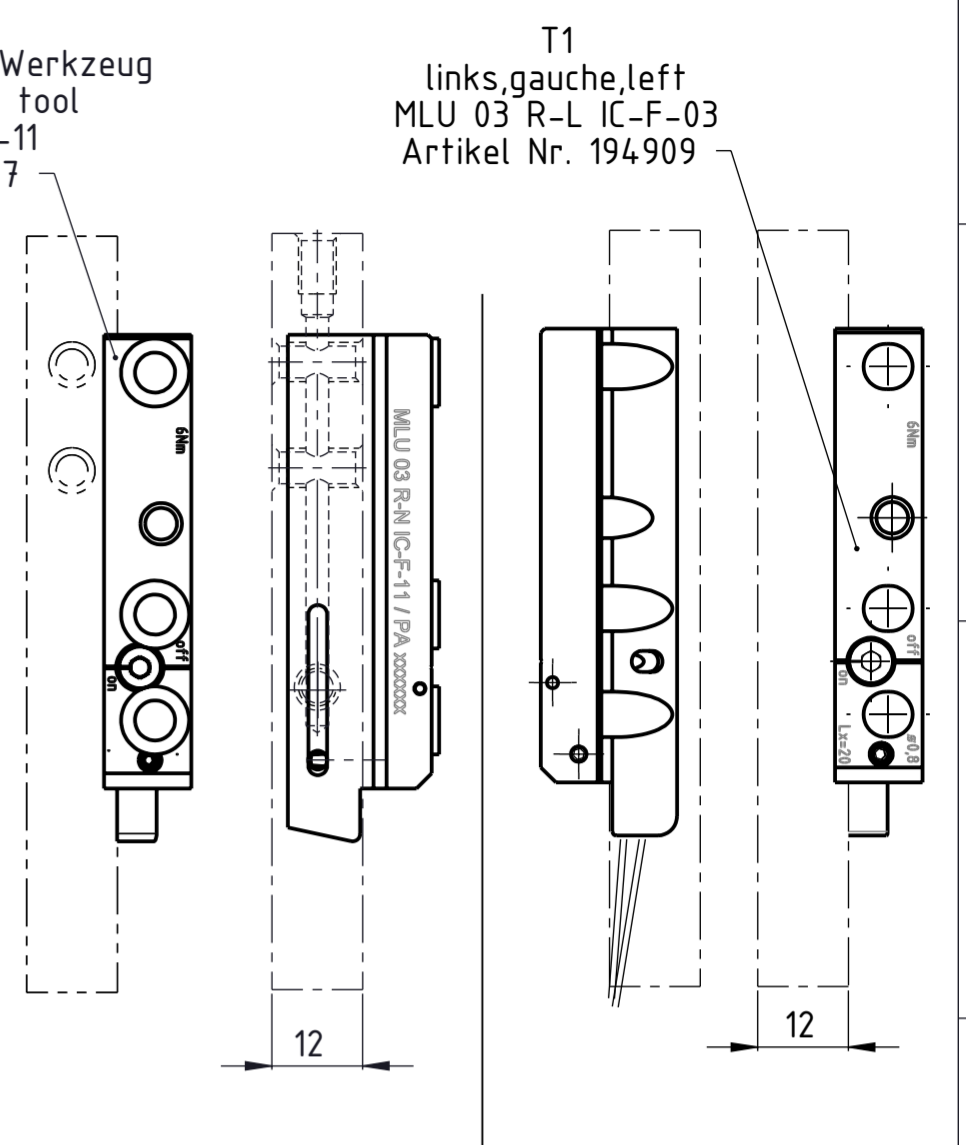
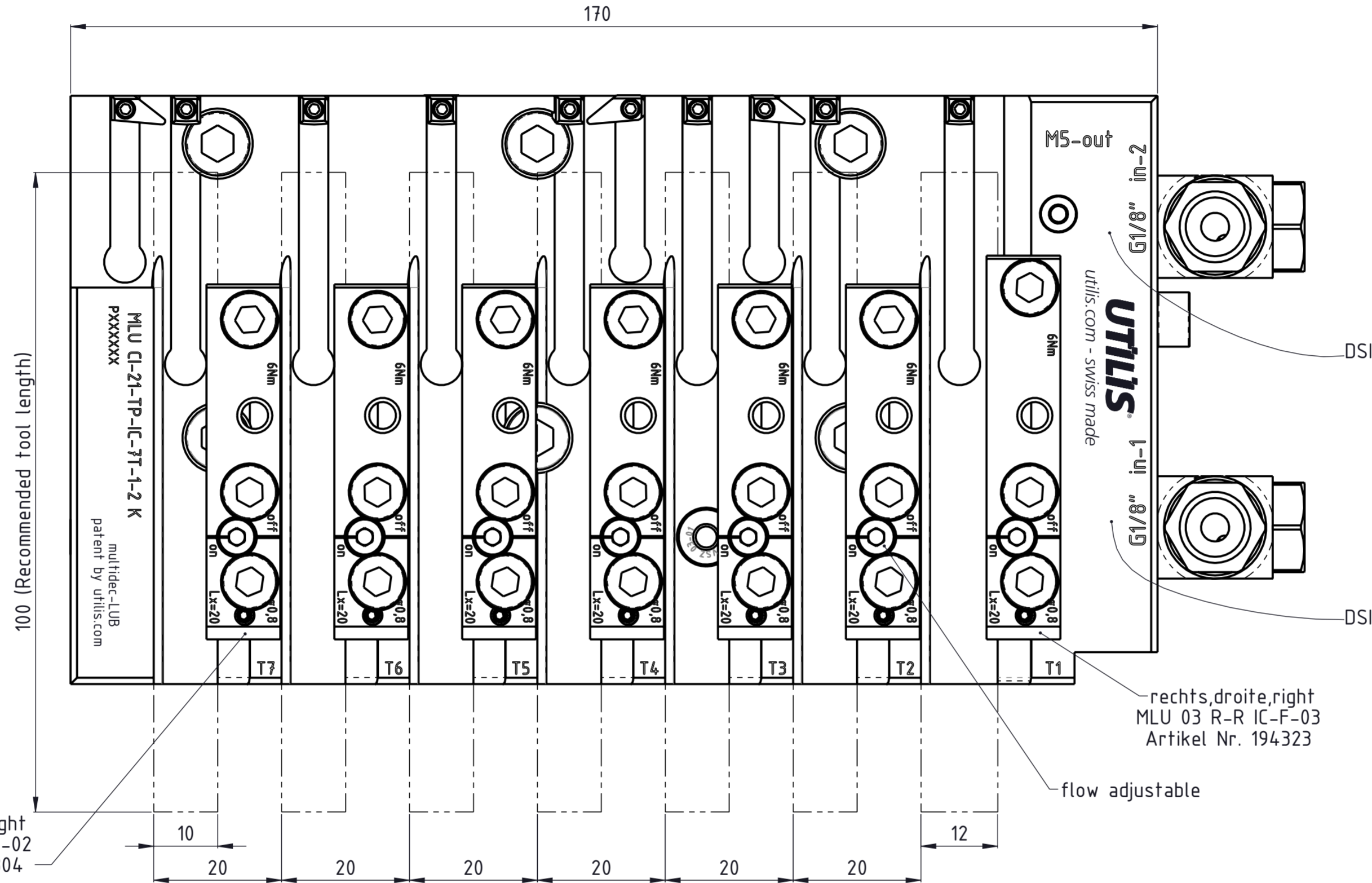
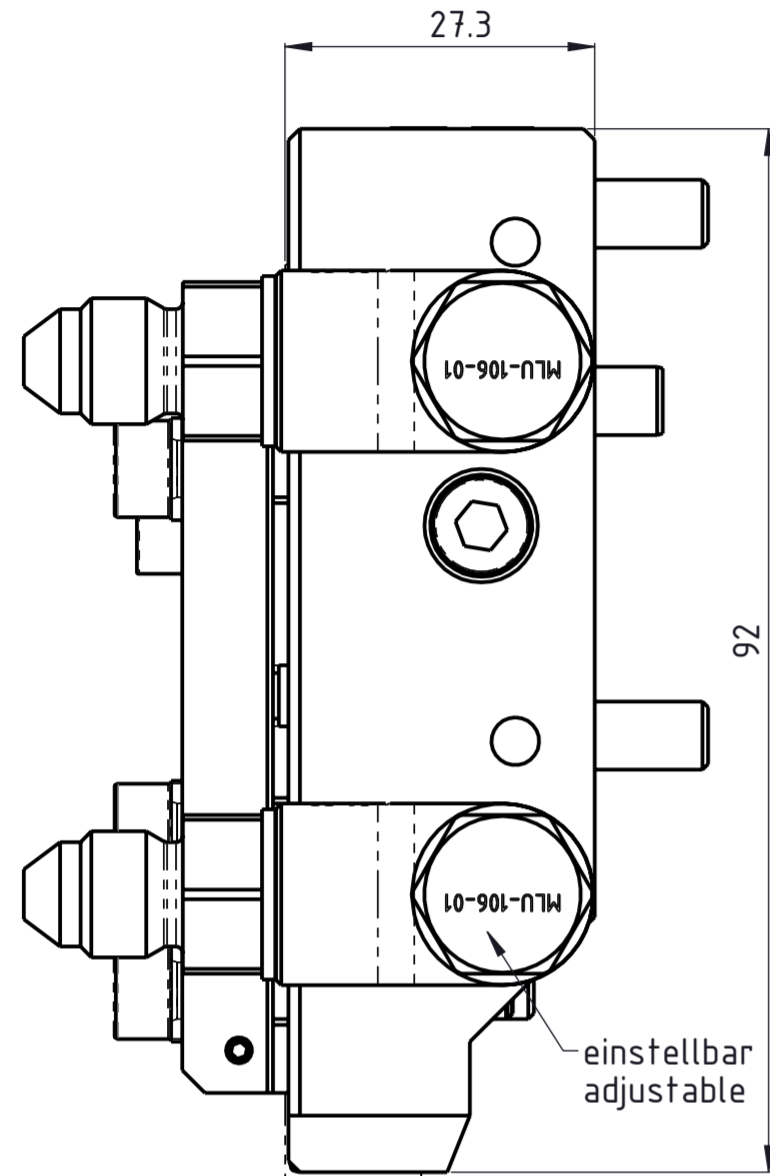

Alle Positionen müssen mit einem Halter bestückt sein!  
 Platzhalter für nicht bestückte Positionen auf Wunsch erhältlich.  
 All positions must be equipped with a holder!  
 Placeholders for unpopulated positions available on request.

Lx=  
 Vorstandlänge des Werkzeuges für optimale Kühlung  
 Longueur d'outil pour un refroidissement optimal  
 Tool length for optimal cooling

Type of machine	Plate number	DSI Docking System in	Tools size
L12 X (L12-2M10)	GTF7110	G1/8"	T1=12/12
L12 X (L12-2M10)	GTF7110	G1/8"	T2-T7=10/10

Beschreibung multidec Werkzeugplatte IC	Artikel Bezeichnung MLU CI-21-TPC-IC-7T-2K	Zeichnungsnummer MLU-112-3-2	<b>UTILIS</b> Tooling for High Technology	Format A2	Index A
--	---	---------------------------------	--	--------------	------------