

front of tool plate

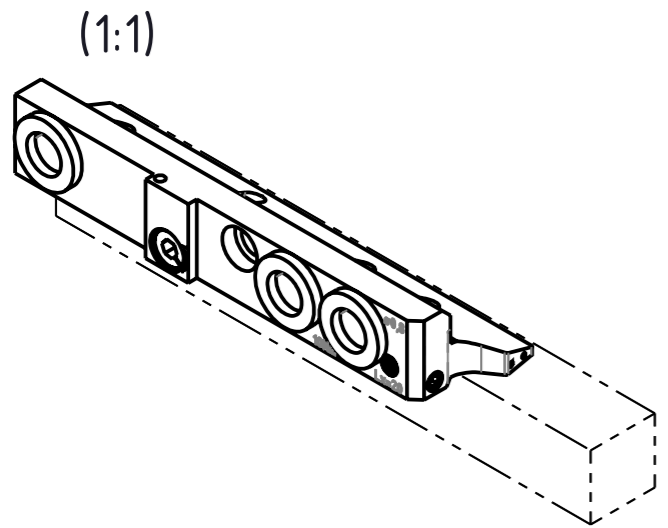

Linke Ausführung
Execution gauche
Left execution

Lx=
Vorstandlänge des Werkzeuges für optimale Kühlung
Longueur d'outil pour un refroidissement optimal
Tool length for optimal cooling

Type of machine	Plate number	Tools size
Citizen L20	GTF-3612/GTF3912	T2-T5 12x12
Citizen L20	GTF-3812	T2-T6 12x12