

links, gauche, left
MLU 01 R-L IC-F-12
Artikel Nr. 215434

tool plate

Lx=20

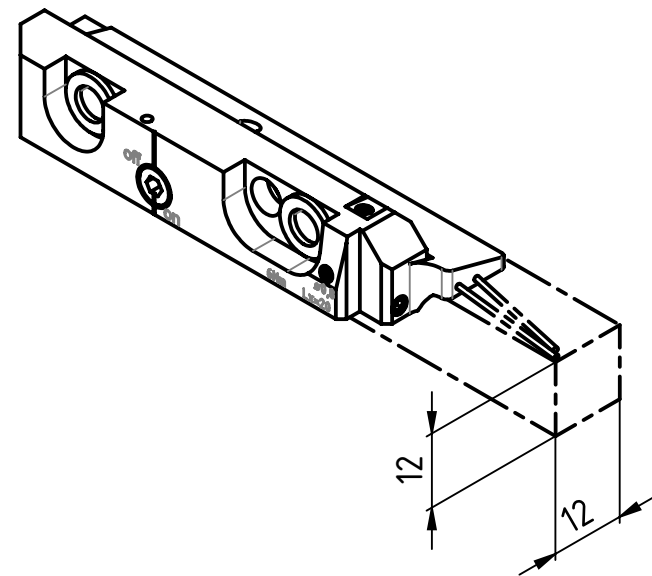
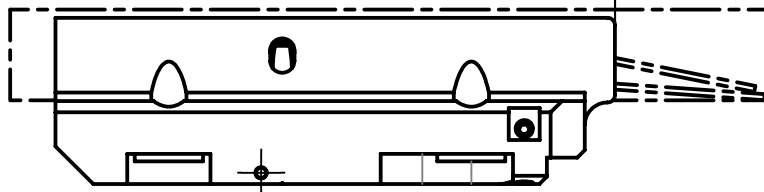

Lx=

Vorstandlänge des Werkzeuges für optimale Kühlung
Longueur d'outil pour un refroidissement optimal
Tool length for optimal cooling

Type of machine	Plate number	Tools size
Tornos GT-13	390223	T120-T124 - 12x12
Tornos GT-13	390224	T211-T212 - 12x12

Beschreibung

multidec-LUB Spannkeil

Artikel Bezeichnung

MLU 01 R-L IC-F-12

Zeichnungsnummer

MLU-125-3-2



Index
A