

Pos. 2+3 nicht im Lieferumfang enthalten  
 Les positions 2et3 ne font pas partie de la fourniture  
 Item 2+3 / not included in delivery

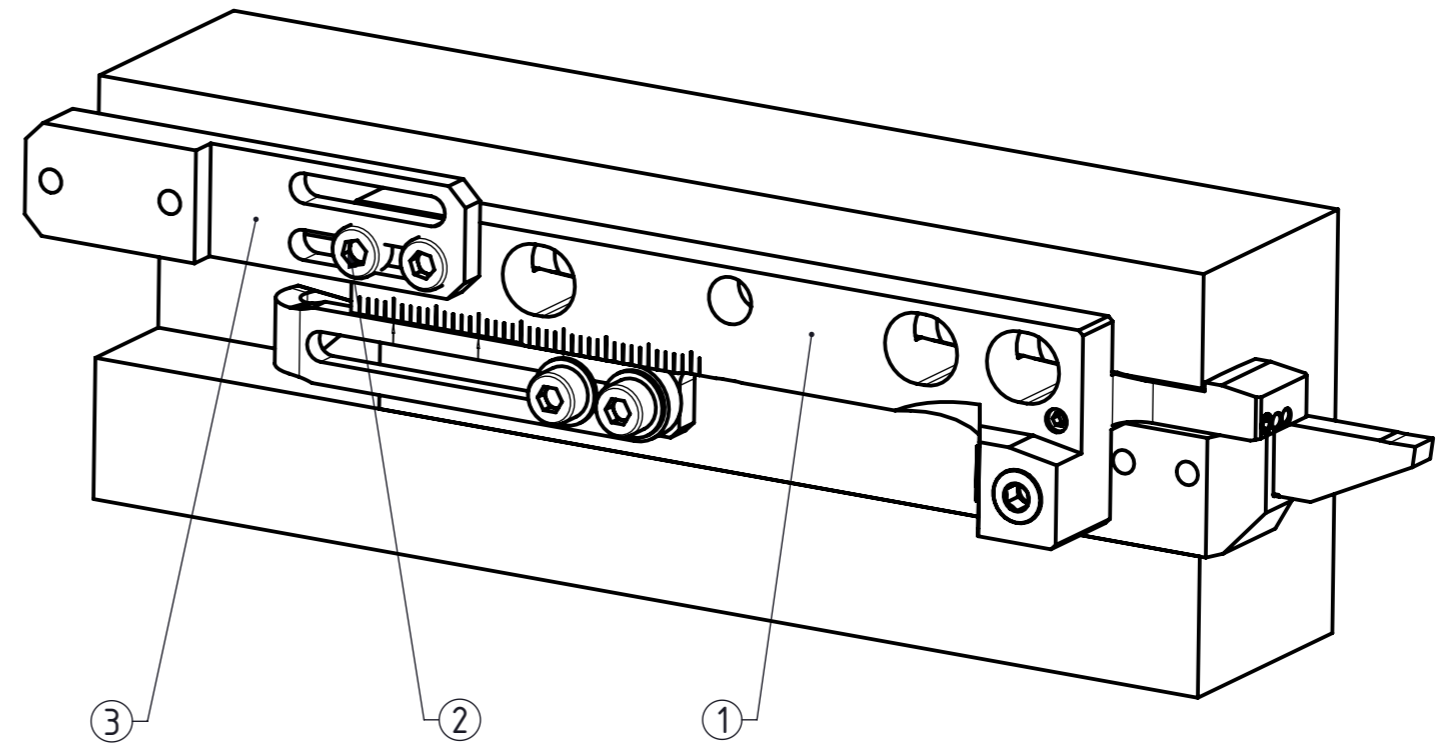
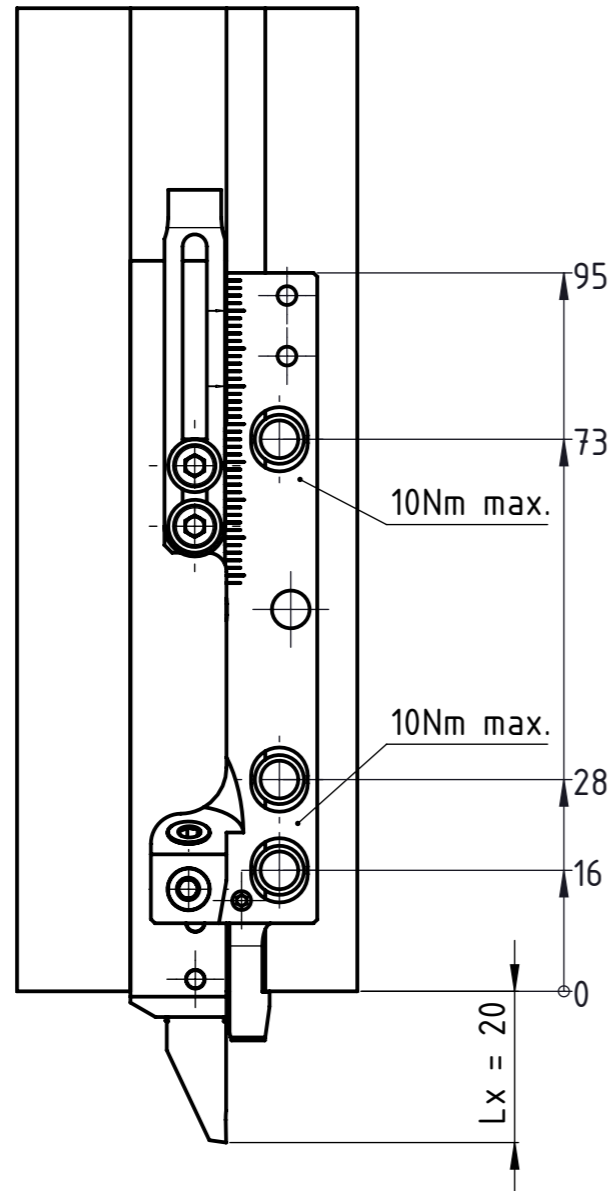
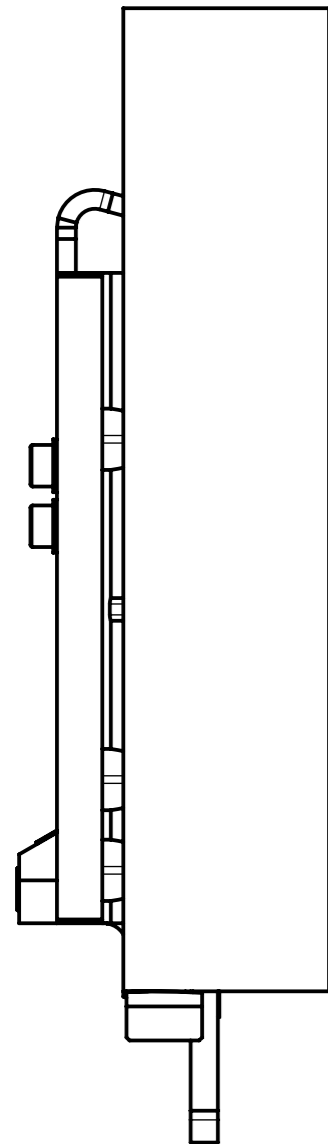
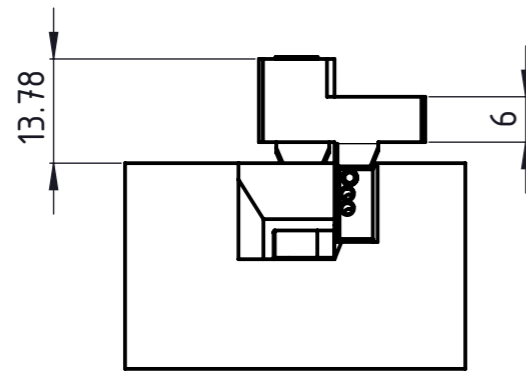

Lx=  
 Vorstandlänge des Werkzeuges für optimale Kühlung  
 Longueur d'outil pour un refroidissement optimal  
 Tool length for optimal cooling

3	1	150258	MLU-34-11-Z	MLU-34-11-Z	MLU- HKV-11
2	4	137802	MSP-70-01	MSP-70-01	MSP 30060 IB2.5
1	1	117082	MLU-28-05-Z	MLU-28-05-Z	MLU CI-03 R-L IC-F
POS.	Menge	Artikelnummer	Z-Nummer	Z-Nummer	Beschreibung

Beschreibung  
 Multidec Lub Keil

Artikel Bezeichnung  
 MLU CI-03 R-L IC-F

Zeichnungsnummer  
 MLU-28-05

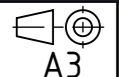

Index  
 C

A3-Kunde-V8