

Halter 12x12

24

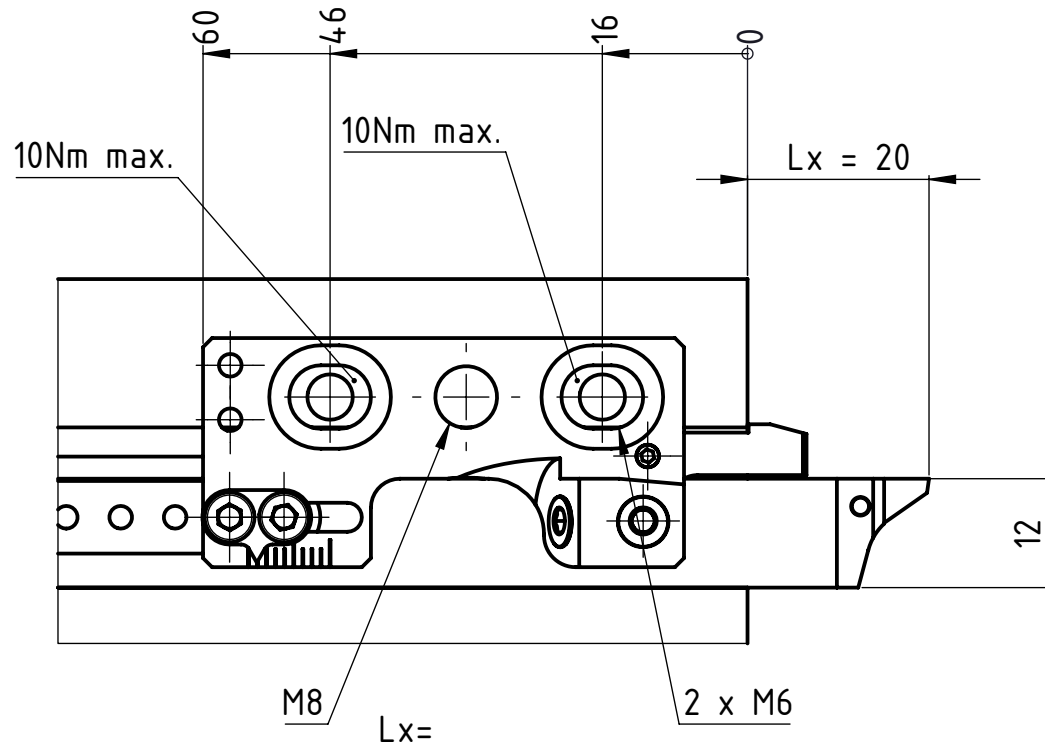
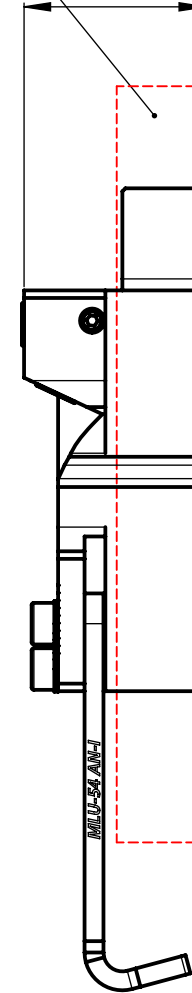

Vorstandlänge des Werkzeuges für optimale Kühlung  
 Longueur d'outil pour un refroidissement optimal  
 Tool length for optimal cooling

Beschreibung

Multidec Lub Keil

Artikel Bezeichnung

MLU TS-02 R-R IC-F

Zeichnungsnummer

MLU-53-01

**UTILIS**<sup>®</sup>  
 Tooling for High Technology

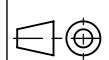

Index  
 F