

Lx =
 Vorstandlänge des Werkzeuges für optimale Kühlung
 Longueur d'outil pour un refroidissement optimal
 Tool length for optimal cooling

Halter 16x16

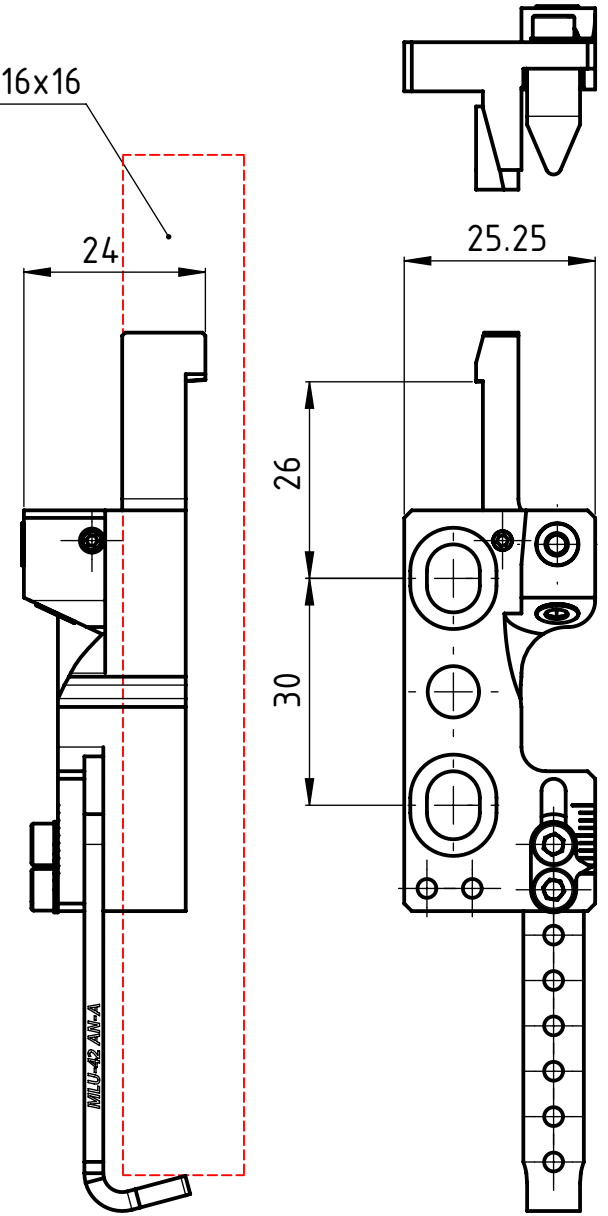

Beschreibung

Multidec Lub Keil

Artikel Bezeichnung

MLU TS-06 R-R IC-F

Zeichnungsnummer

MLU-53-10

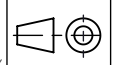

Index
C