

1 2 3 4 5 6

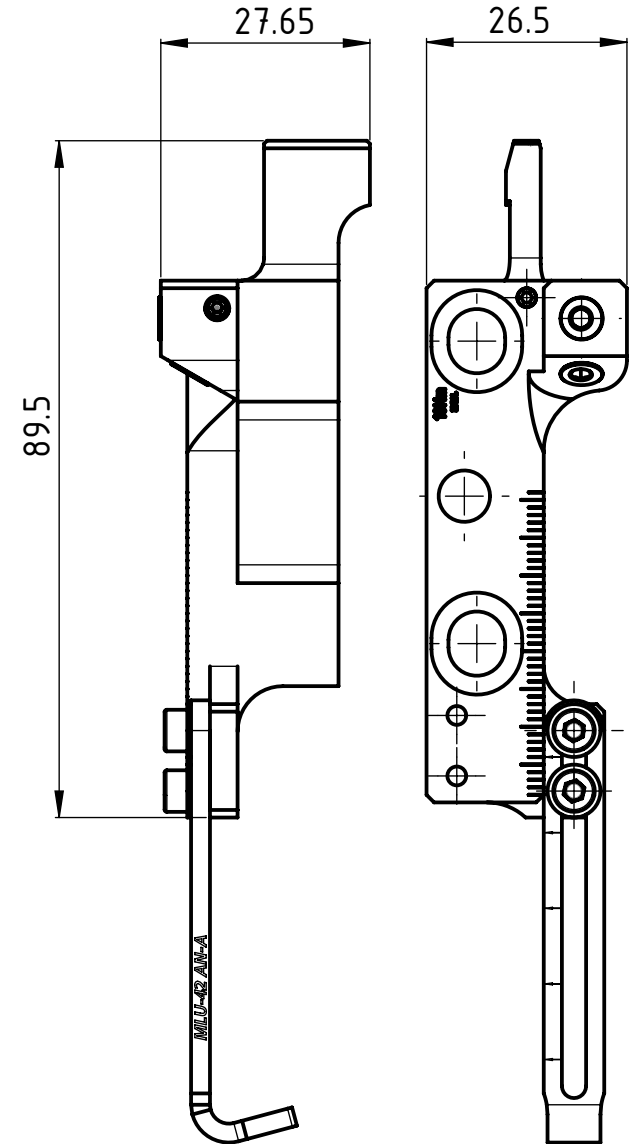
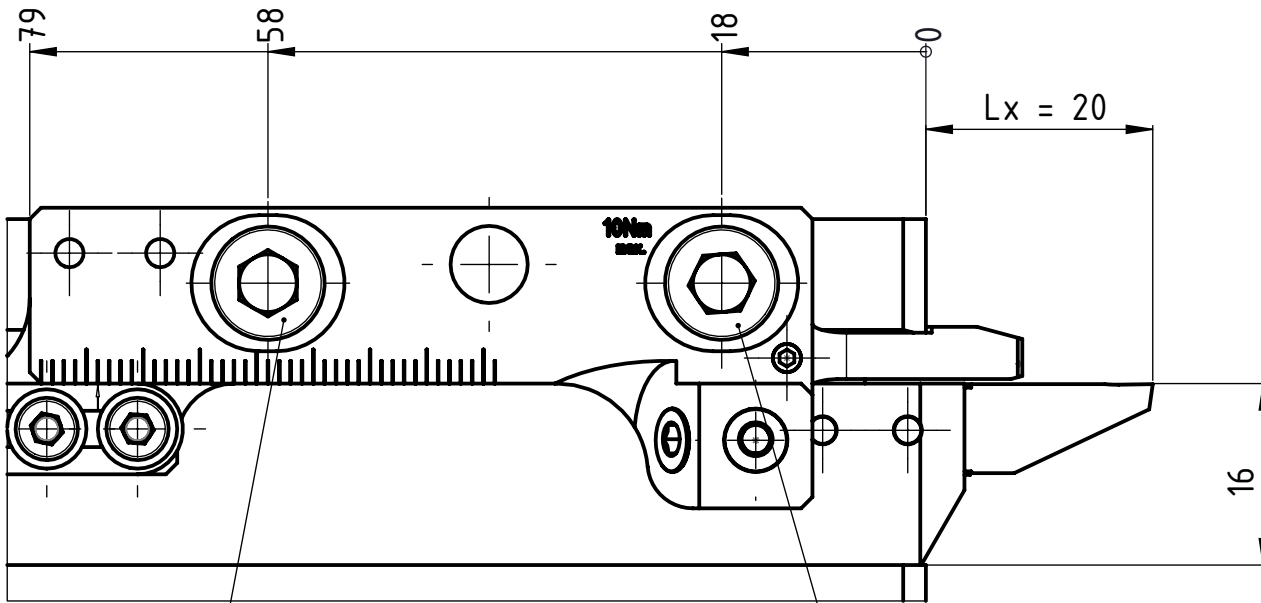
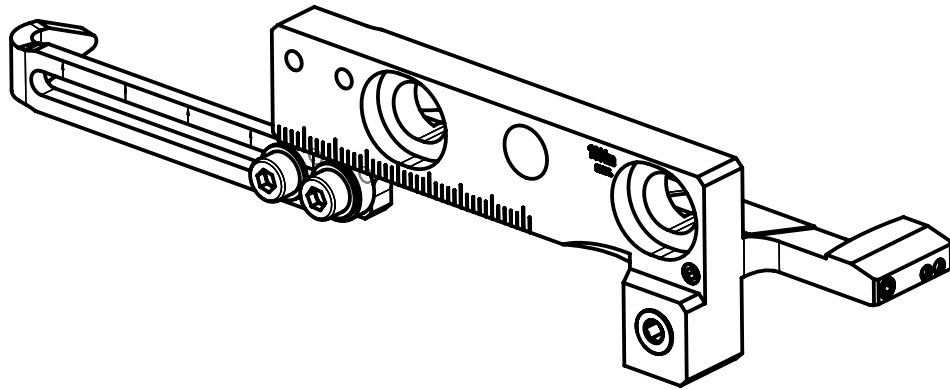

10Nm max.      10Nm max.

Lx =  
 Vorstandlänge des Werkzeuges für optimale Kühlung  
 Longueur d'outil pour un refroidissement optimal  
 Tool length for optimal cooling

Beschreibung

Multidec Lub Keil

Artikel Bezeichnung

MLU T0-03 R-R IC F

Zeichnungsnummer

MLU-70-01

**UTILIS**<sup>®</sup>  
 Tooling for High Technology

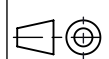

Index  
 A