

Lx=  
 Vorstandlänge des Werkzeuges für optimale Kühlung  
 Longueur d'outil pour un refroidissement optimal  
 Tool length for optimal cooling

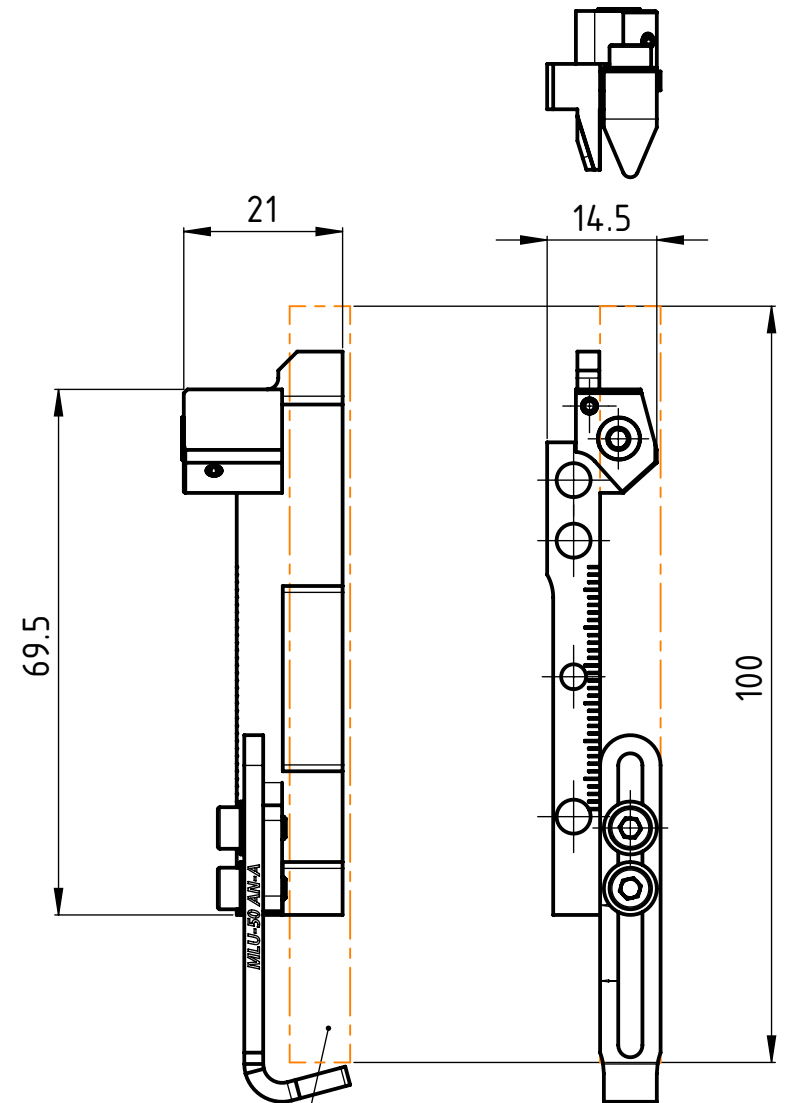

Halter 8x8

Beschreibung

MLU CI-10 R-R IC-F

Artikel Bezeichnung

MLU CI-10 R-R IC-F

Zeichnungsnummer

MLU-76-03

**UTILIS**<sup>®</sup>  
 Tooling for High Technology

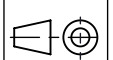

Index  
 A