

1 2 3 4 5 6

A

A

B

B

C

C

D

D

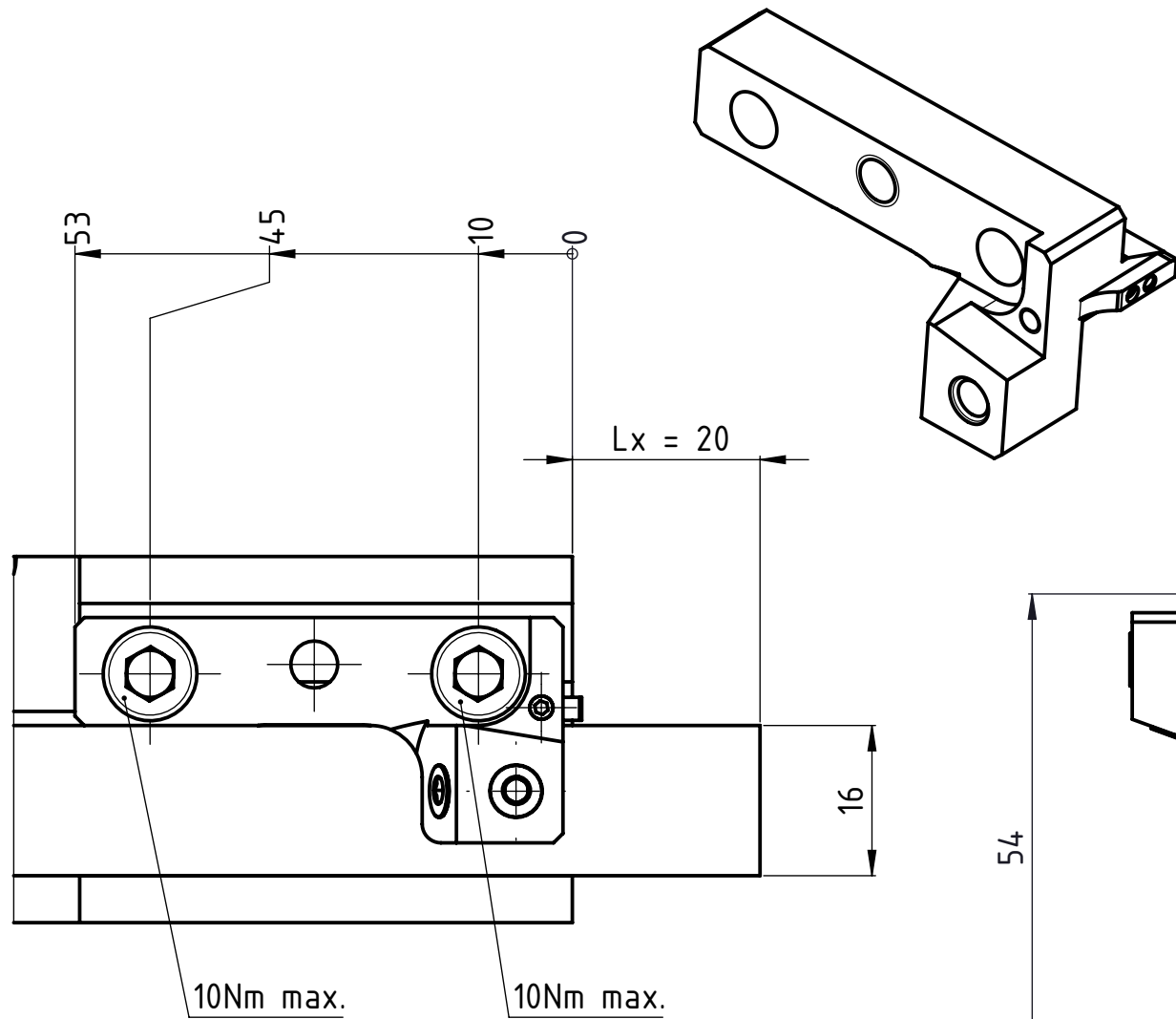

Halter 16x16

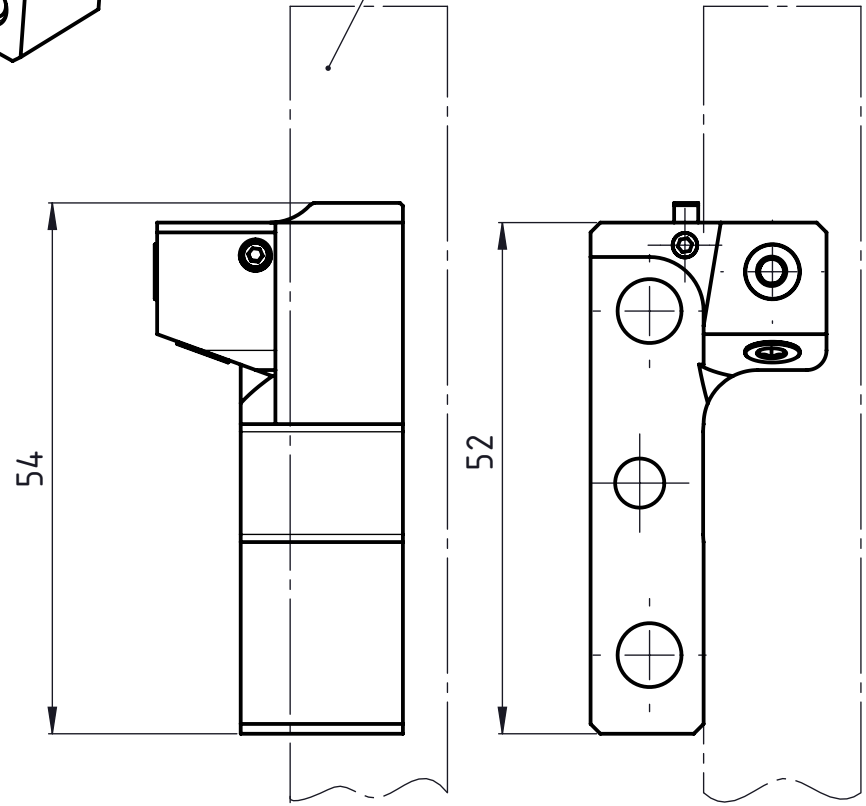

Lx =
 Vorstandlänge des Werkzeuges für optimale Kühlung
 Longueur d'outil pour un refroidissement optimal
 Tool length for optimal cooling

Beschreibung

Multidec Lub Keil

Artikel Bezeichnung

MLU GM-02 R-L IC-F

Zeichnungsnummer

MLU-77-02

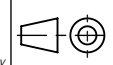

Index

-