

Halter 12x12

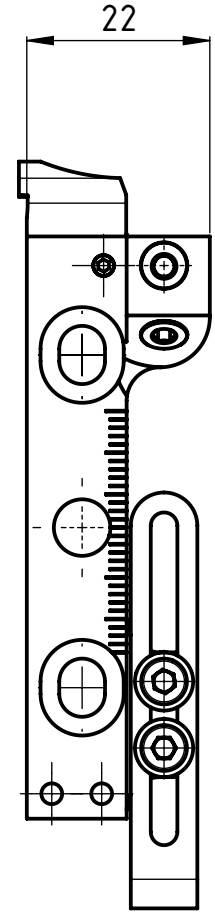
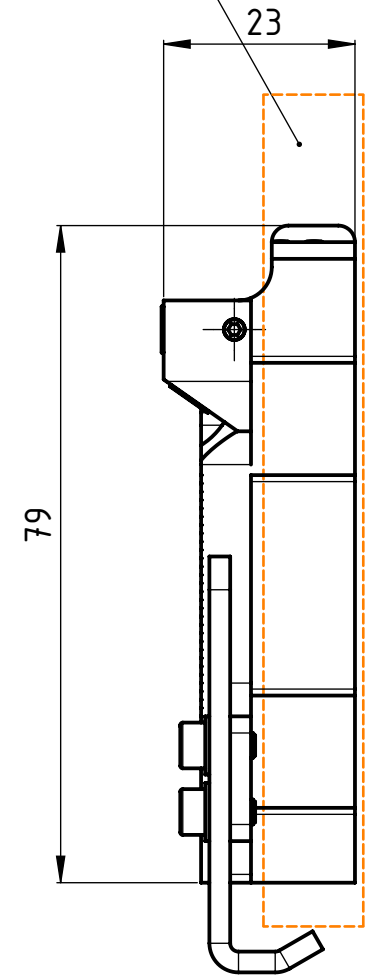
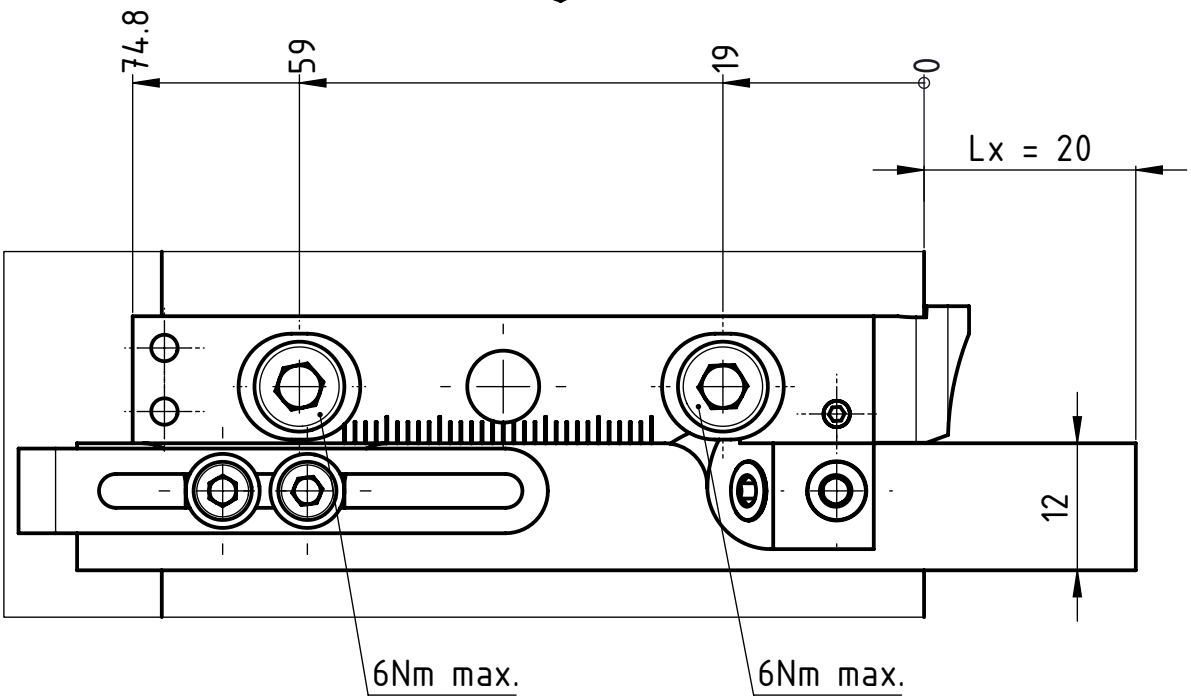
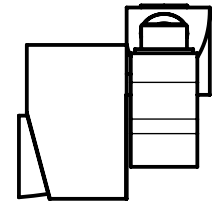

Lx=
 Vorstandlänge des Werkzeuges für optimale Kühlung
 Longueur d'outil pour un refroidissement optimal
 Tool length for optimal cooling

Beschreibung

Multidec Lub Spannkeil

Artikel Bezeichnung

MLU TO-07 R-L IC-F

Zeichnungsnummer

MLU-79-02

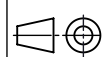

Index
B