

Halter / Holder 10x10

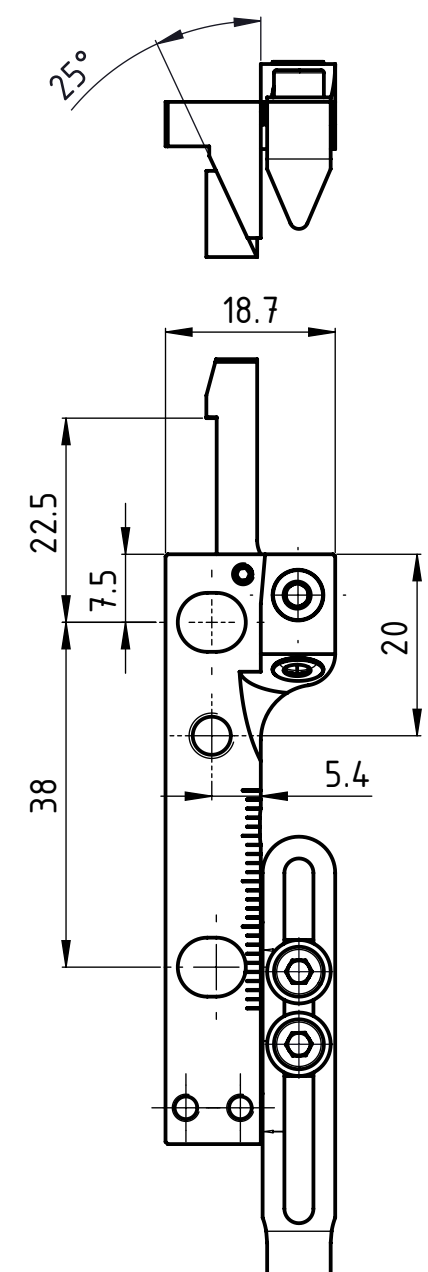
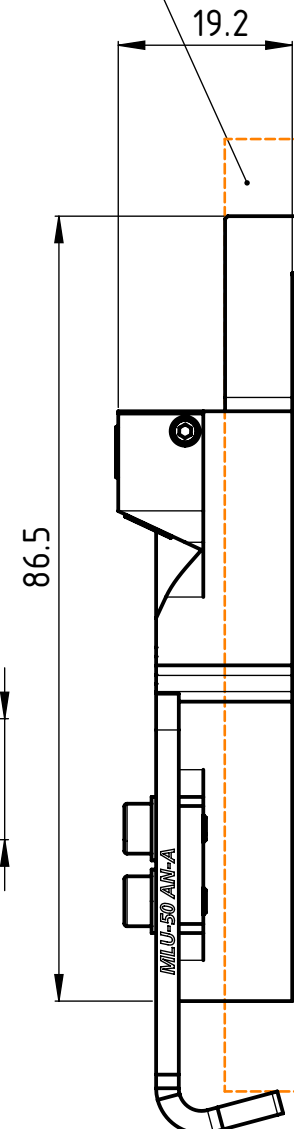
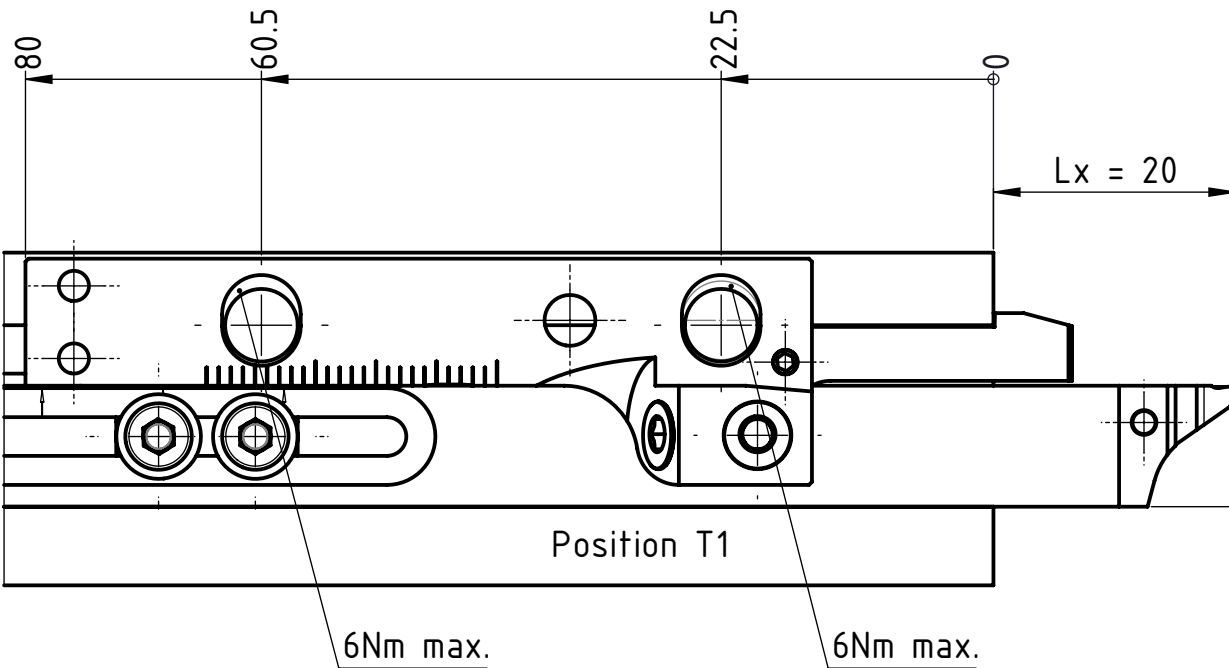

Lx =
 Vorstandlänge des Werkzeuges für optimale Kühlung
 Longueur d'outil pour un refroidissement optimal
 Tool length for optimal cooling

Beschreibung

multidec Lub Keil

Artikel Bezeichnung

MLU ST-21 R-R IC-F

Zeichnungsnummer

MLU-81-05

UTILIS[®]
 Tooling for High Technology

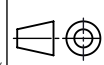

Index
 C