

Halter / Holder 10x10

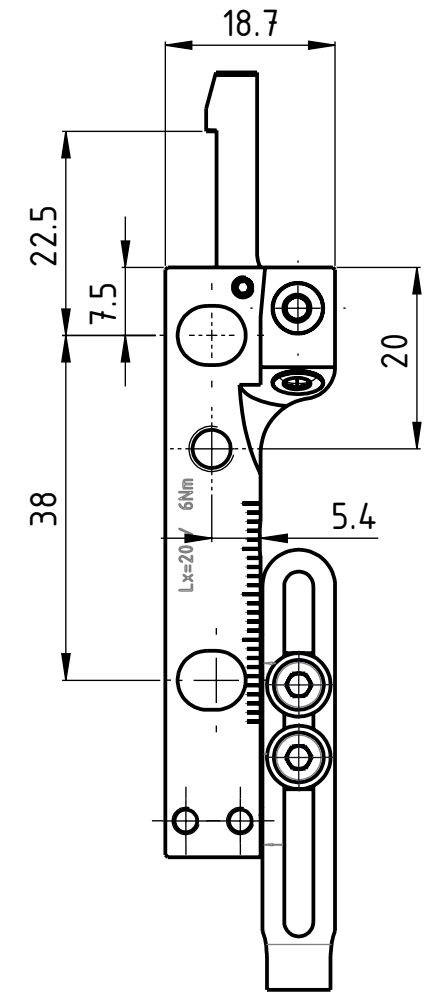
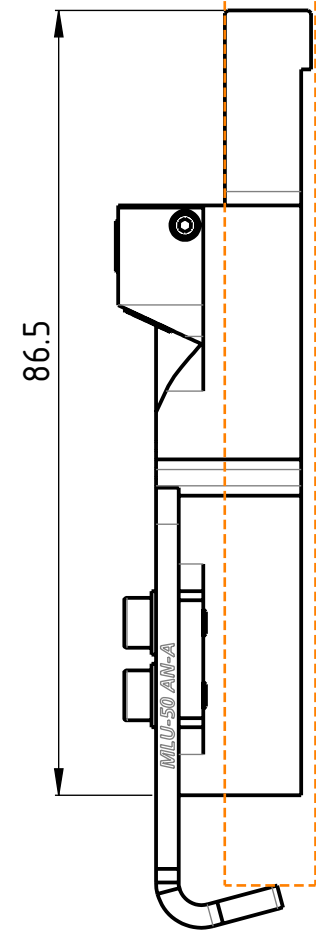
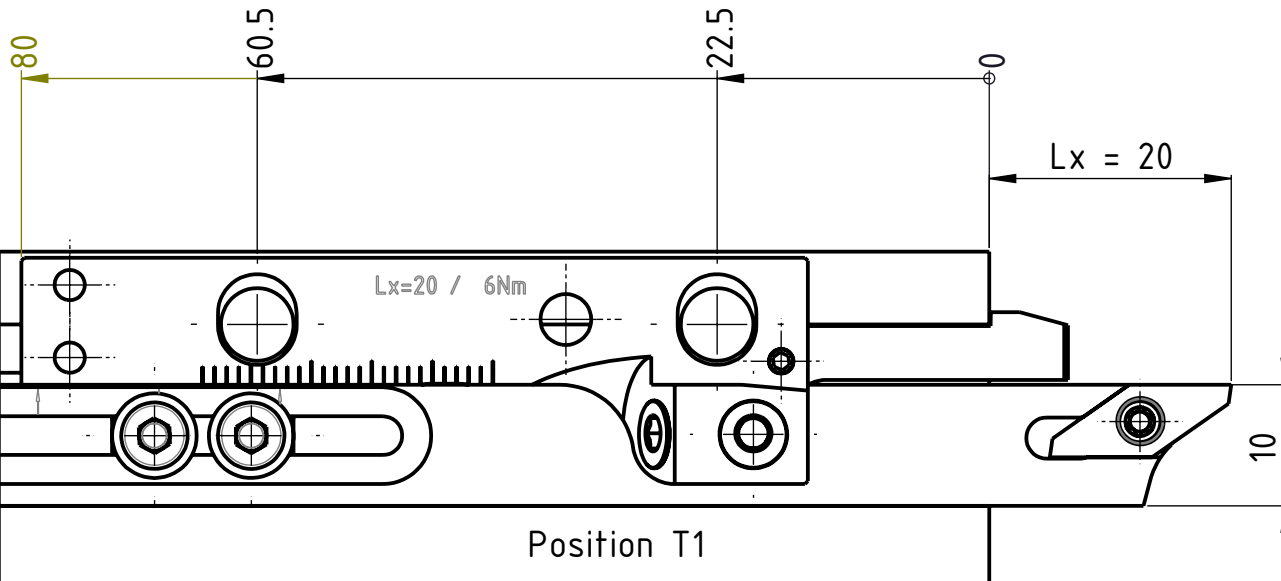
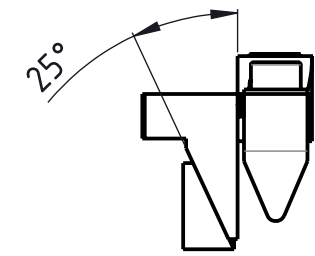
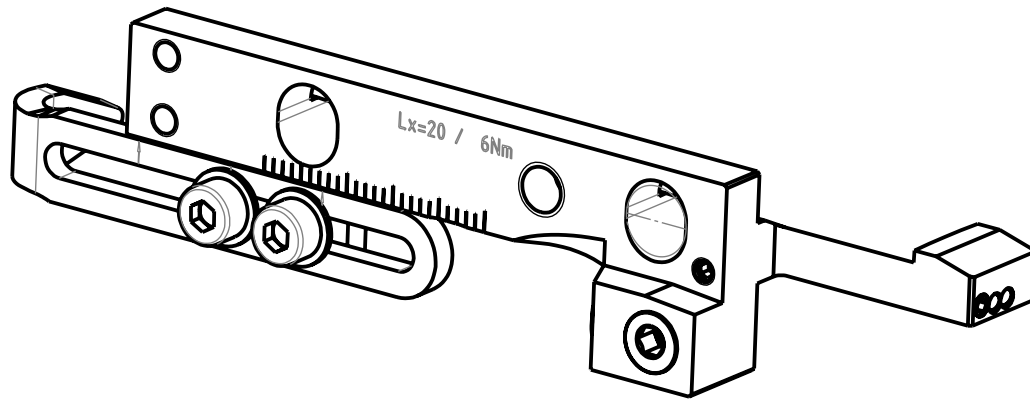

Lx=
 Vorstandlänge des Werkzeuges für optimale Kühlung
 Longueur d'outil pour un refroidissement optimal
 Tool length for optimal cooling

Beschreibung

multidec Lub Keil

Artikel Bezeichnung

MLU ST-21 R-L IC-F

Zeichnungsnummer

MLU-81-6

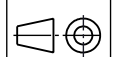

Index
 -