

1 2 3 4 5 6

A  
B  
C  
D

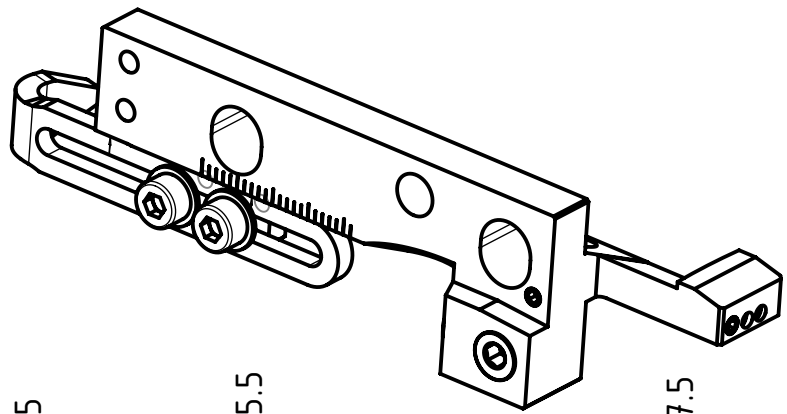

Halter 12x12

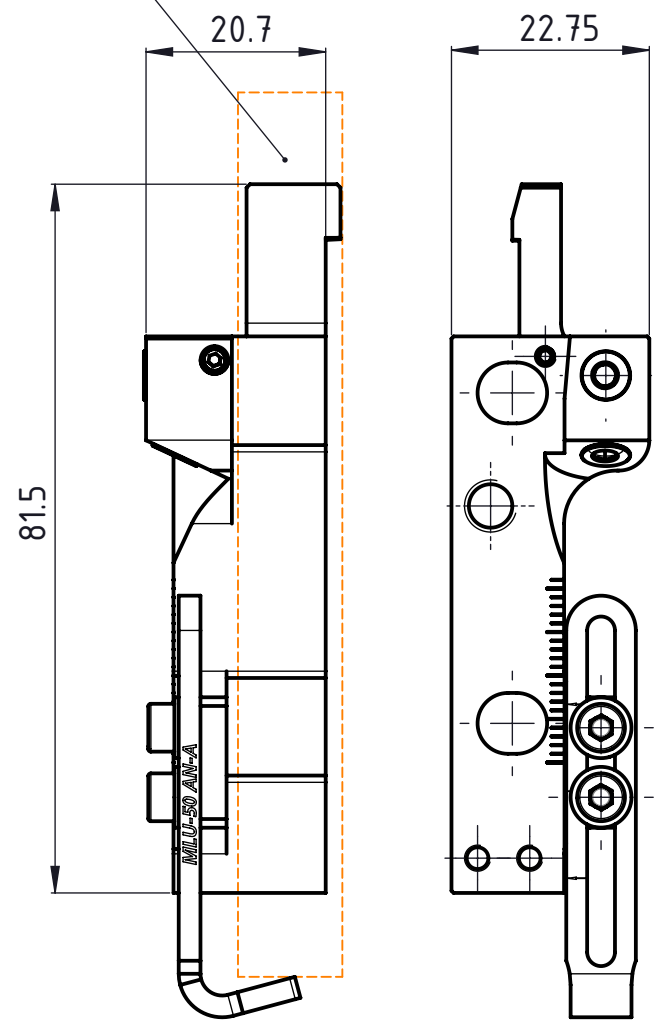
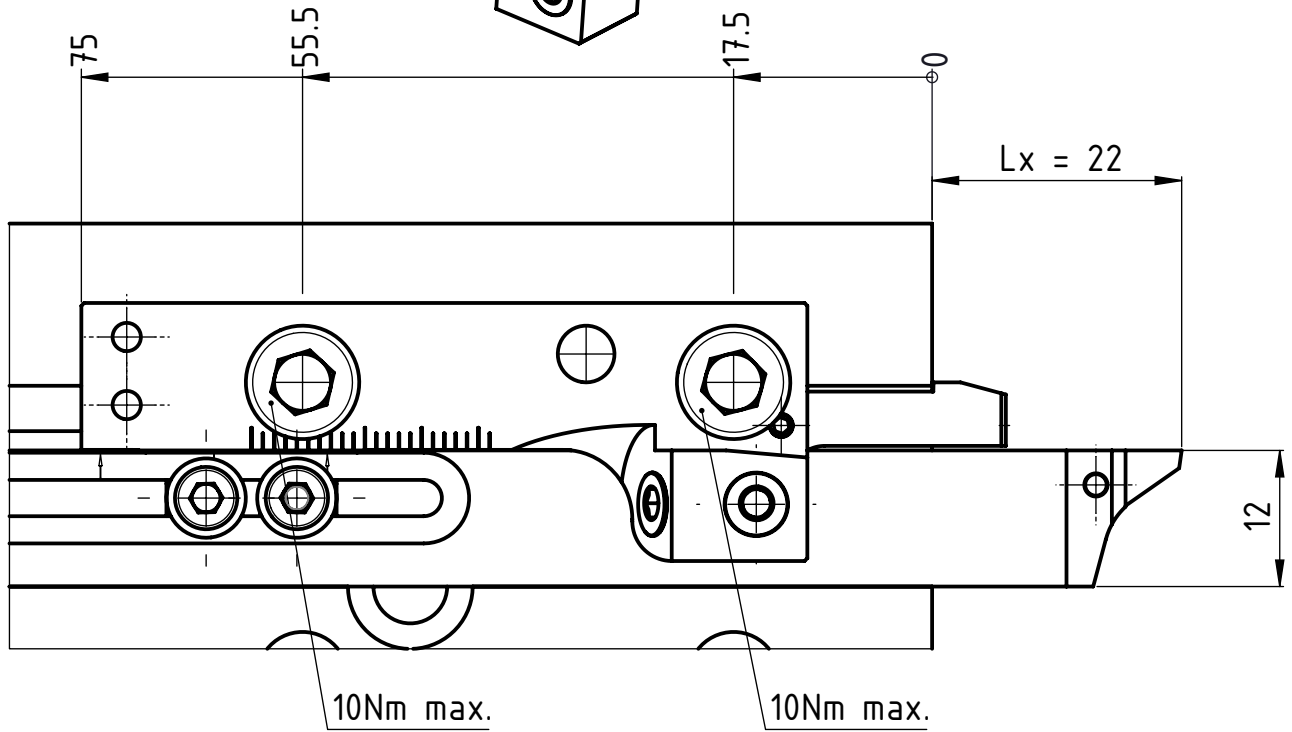

Lx=  
Vorstandlänge des Werkzeuges für optimale Kühlung  
Longueur d'outil pour un refroidissement optimal  
Tool length for optimal cooling

Beschreibung

Multidec Lub Keil

Artikel Bezeichnung

MLU ST-15 R-R IC-F

Zeichnungsnummer

MLU-84-01

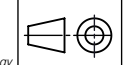

Index

-