

2 Kühlkreislauf System
in-#1 T1-T5 out
in-#2 T6-T9 out

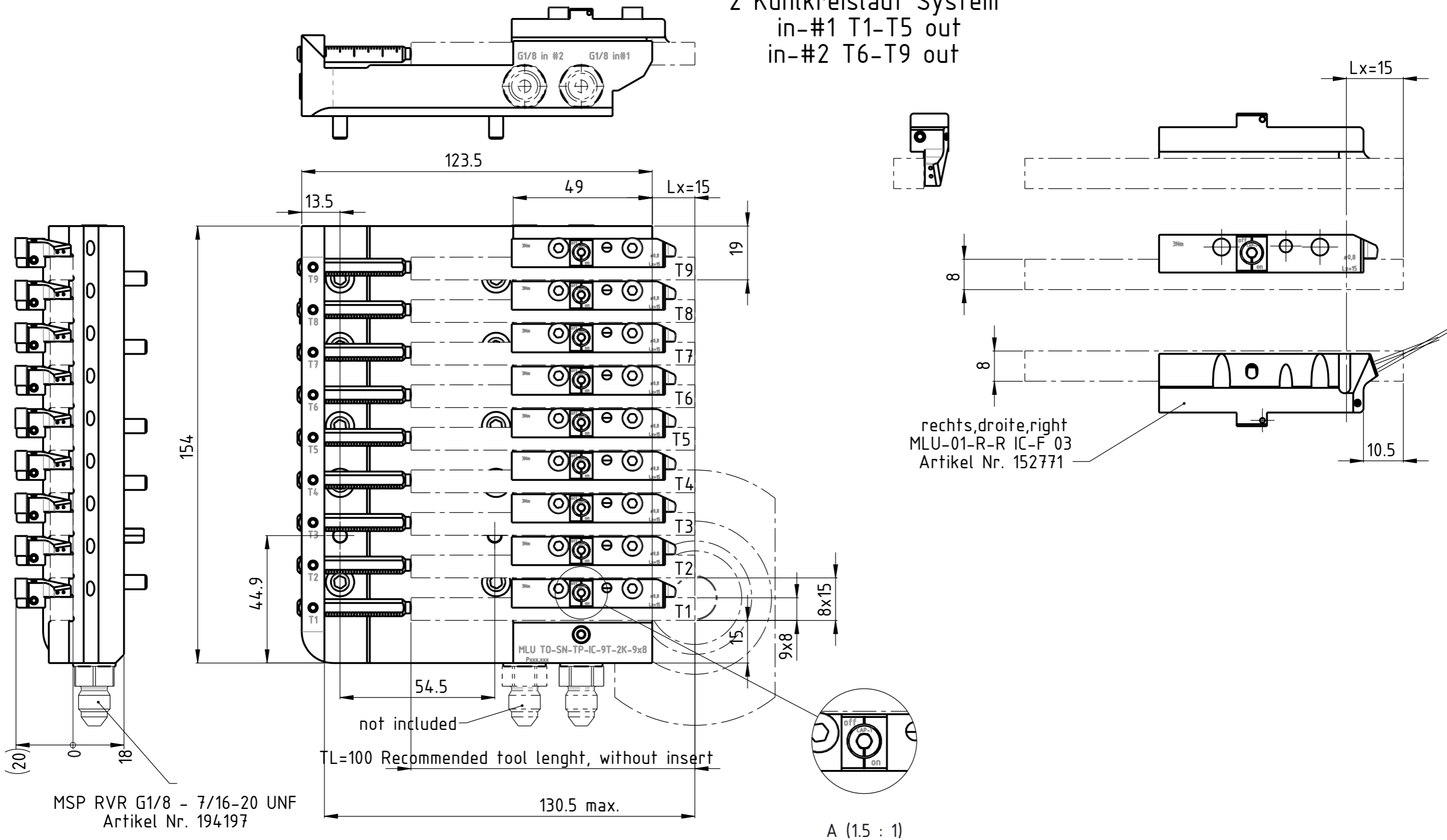

MSP RVR G1/8 - 7/16-20 UNF
Artikel Nr. 194197

Recommended tool length, without insert TL = 100mm
with insert ISO / TOP .. TL= 100mm
with insert Cut 16 .. TL= 105mm
with insert Cut 30 .. / 36... (short insert) TL = 111mm
with insert Cut 30 .. (long insert) TL = 117mm

Lx=
Vorstandlänge des Werkzeuges für optimale Kühlung
Longueur d'outil pour un refroidissement optimal
Tool length for optimal cooling

Type of machine	T1-T9
Tornos SwissNano 7	8/8

Beschreibung
multidec-LUB Werkzeugplatte komplett

Artikel Bezeichnung
MLU TO-SN-TPC-IC-9T-2K-9x8

Zeichnungsnummer
MLU-91-5-2

UTILIS
Tooling for High Technology

A3 Index
-