

SCHNITT A-A
MAßSTAB 2 : 1

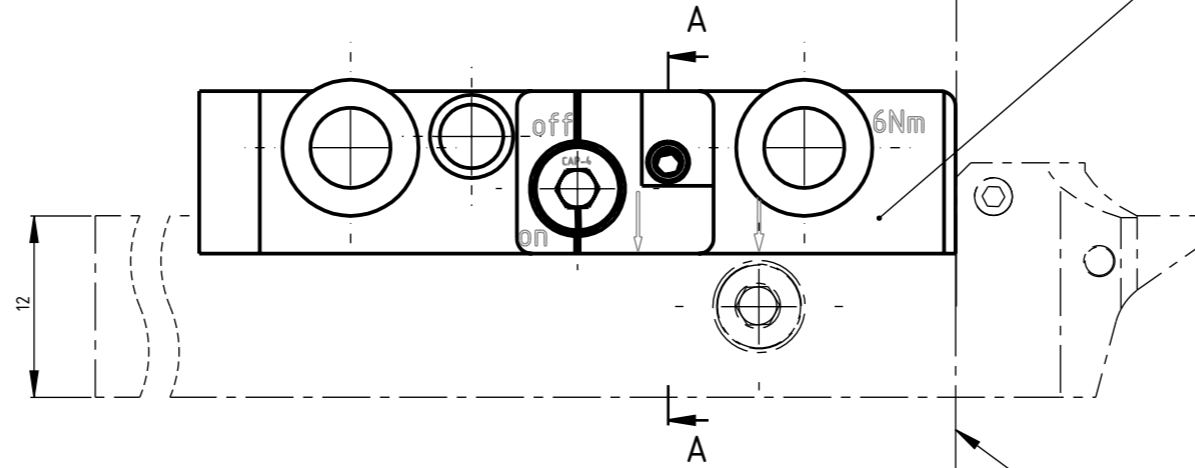

Kühlmittelübergabe an Tools T1
MLU 01 R-N IC-F-14
Artikel Nr. 215754

Tool Plate

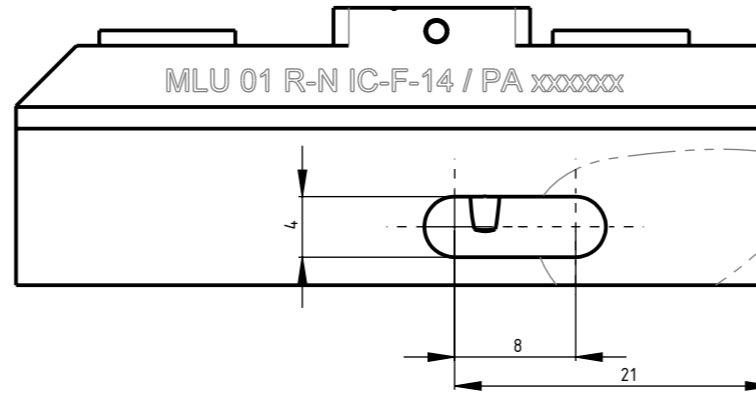
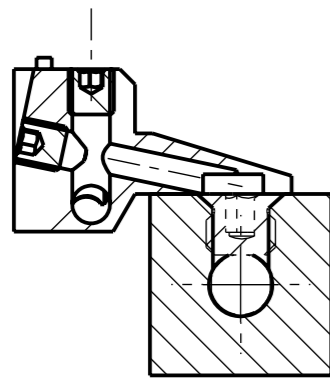
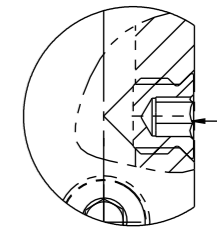
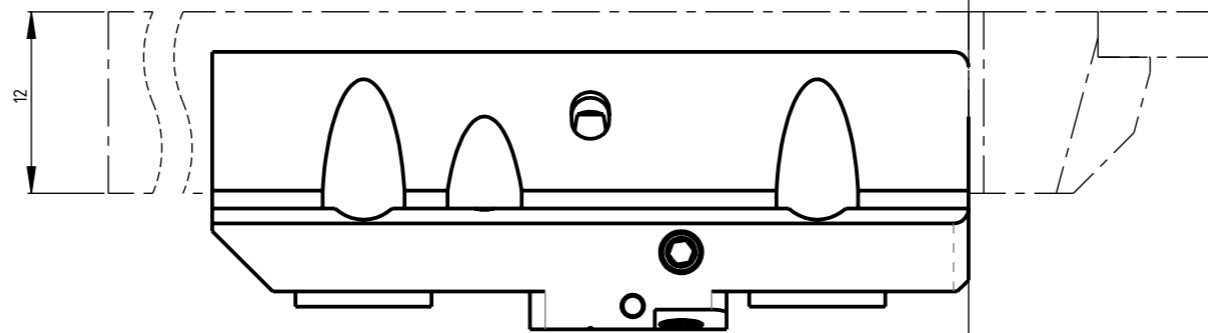

B (2 : 1)

kann bei nicht gebrauch
verschlossen werden MSP VSR M5 B2,5 / Artikel Nr. 150262

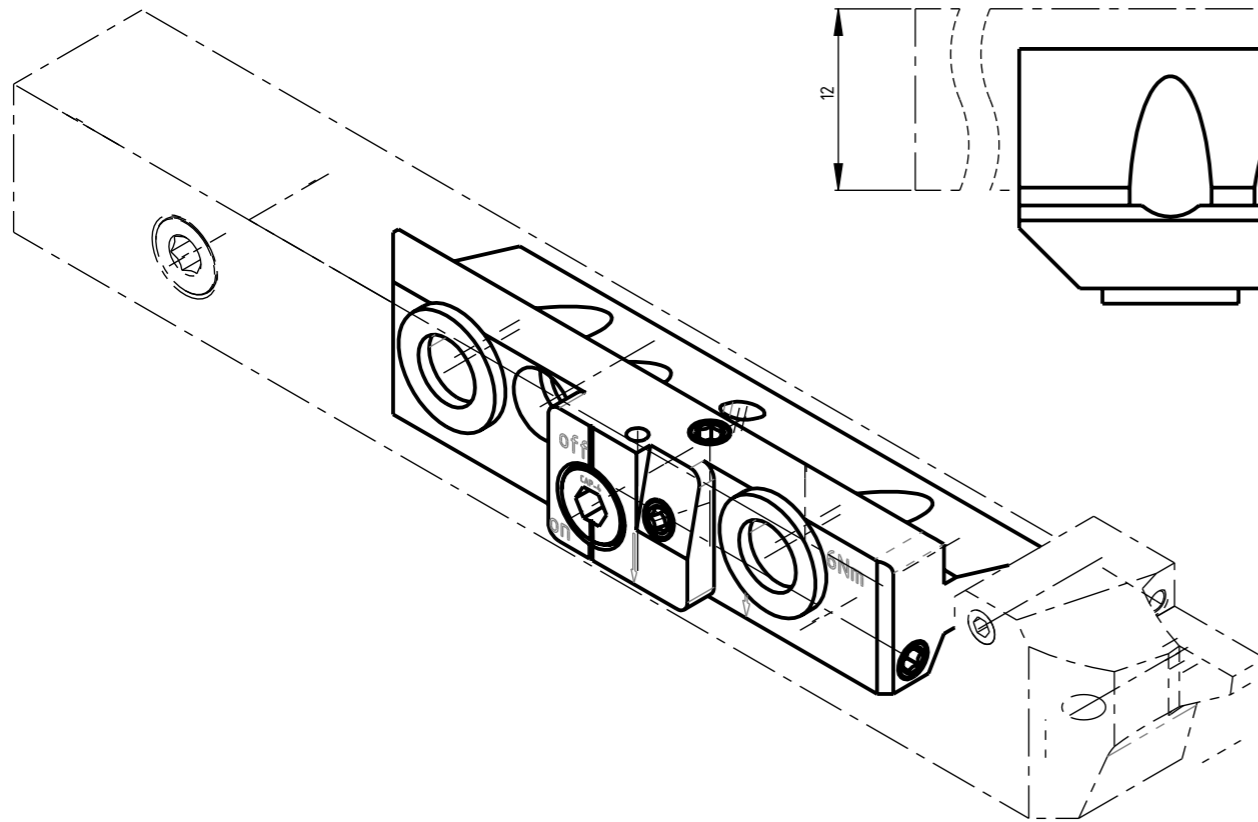
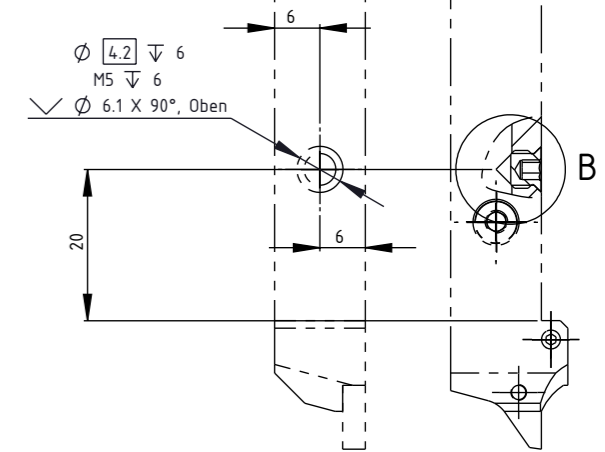
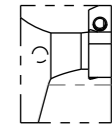

Lx=
Vorstandlänge des Werkzeuges für optimale Kühlung
Longueur d'outil pour un refroidissement optimal
Tool length for optimal cooling

Type of machine	Tools size
SwissNano7	(T1)12x12
UTILIS Tooling for High Technology	
A3	Index -

Beschreibung
Utilis multidec-Spannkeil

Artikel Bezeichnung
MLU 01 R-R IC-F-14

Zeichnungsnummer
MLU-91-6-4-1

A3-Kühler-V8