

Holder 5/8"

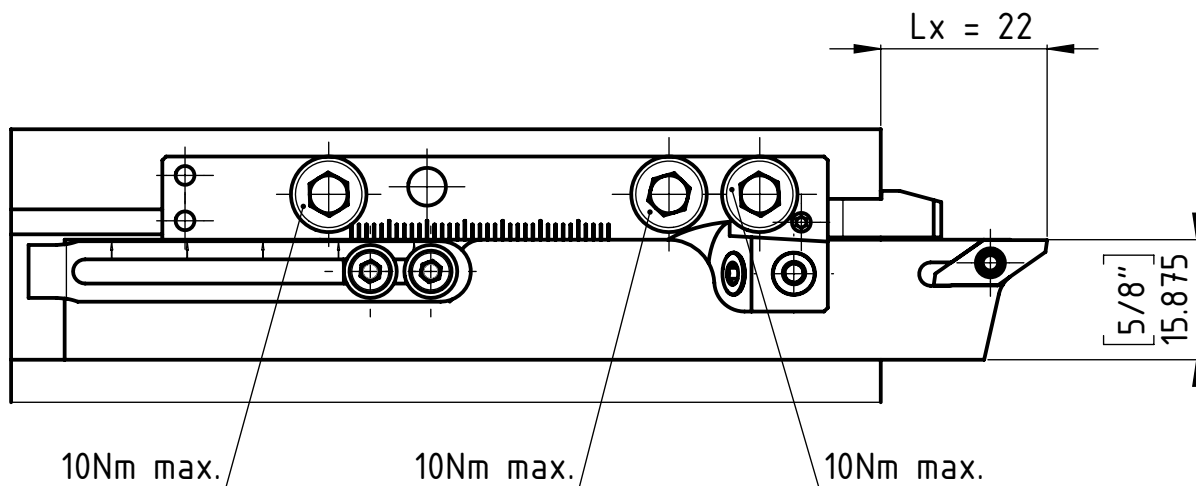

10Nm max.

10Nm max.

10Nm max.

Lx =
 Vorstandlänge des Werkzeuges für optimale Kühlung
 Longueur d'outil pour un refroidissement optimal
 Tool length for optimal cooling

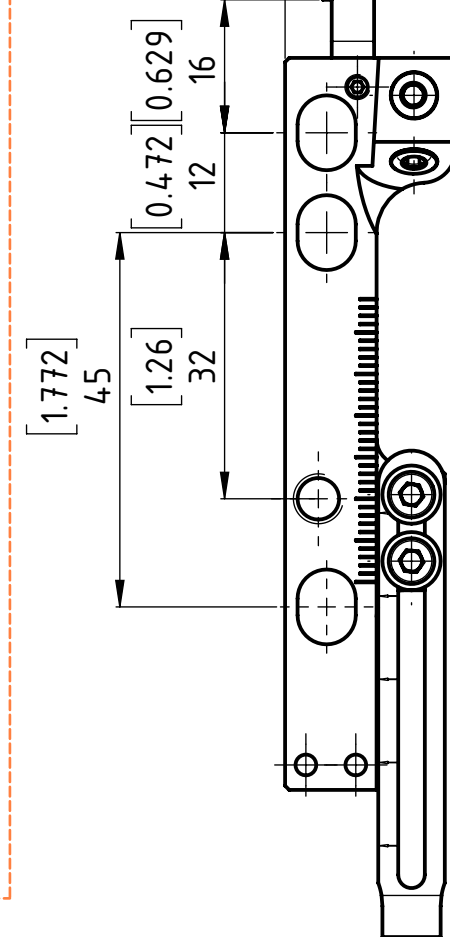
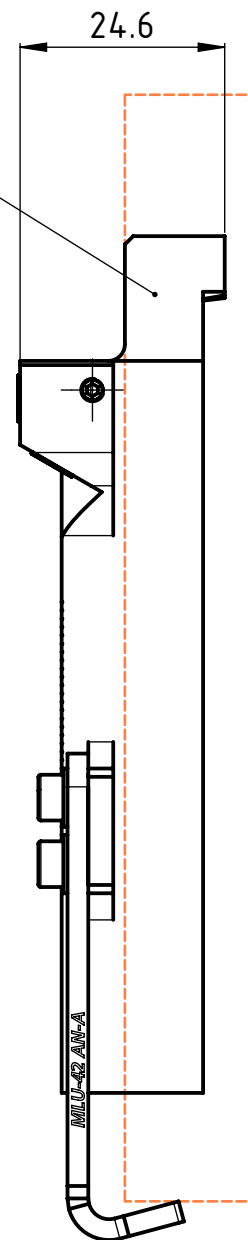

Beschreibung

LUB Spannkeil

Artikel Bezeichnung

MLU CI-11 R-L IC-F

Zeichnungsnummer

MLU-95-02

UTILIS
 Tooling for High Technology



Index
 B