

1 Cooling circuit  
 in#1 out T1-T5  
 in#2 out T1-T5  
 1xM5-out (T1)

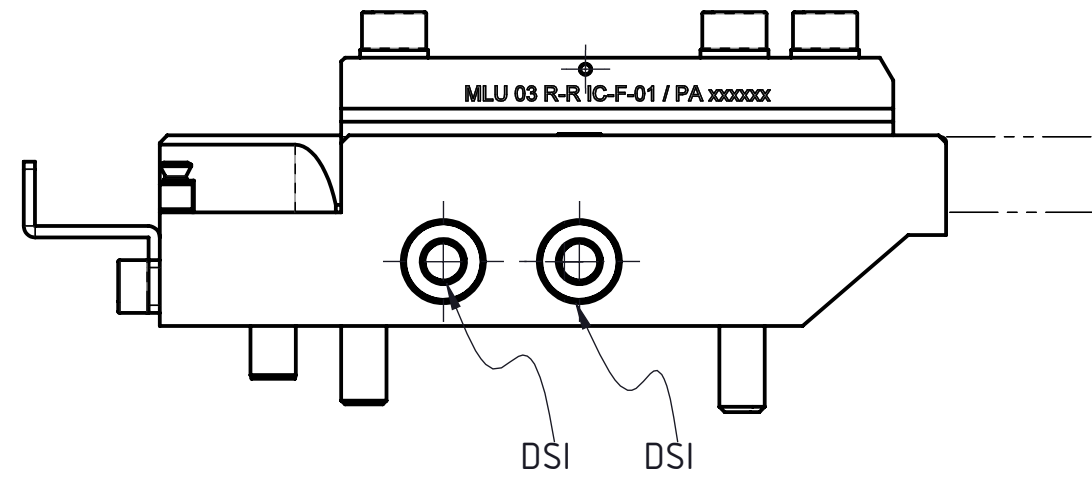

rechts, droite, right  
 MLU 03 R-R IC-F-01  
 Artikel Nr. 194291

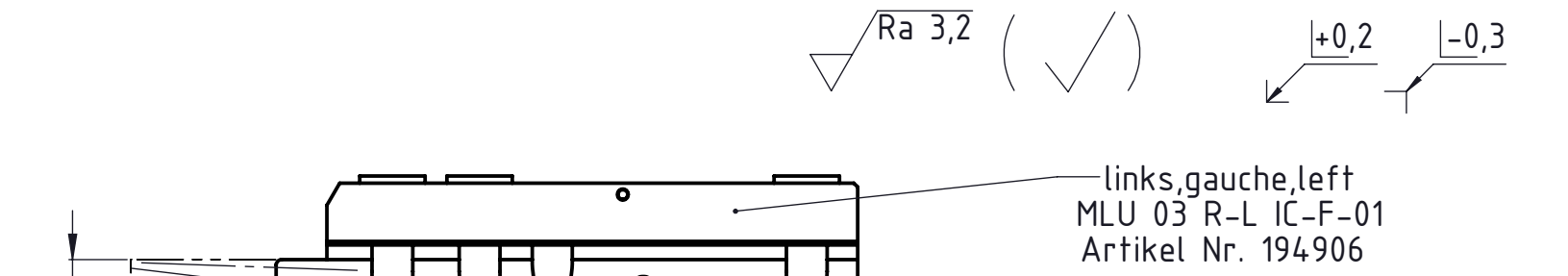
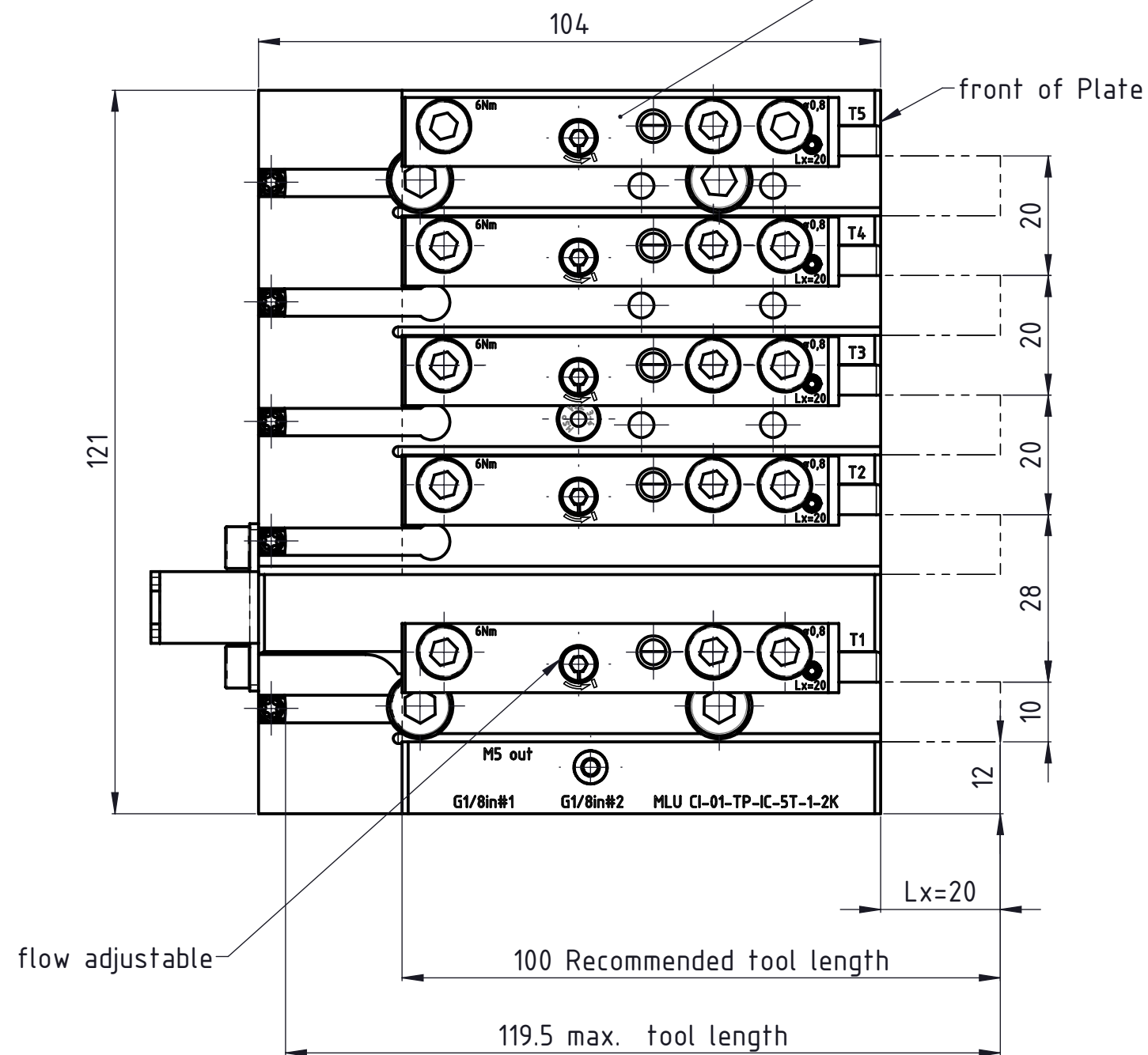
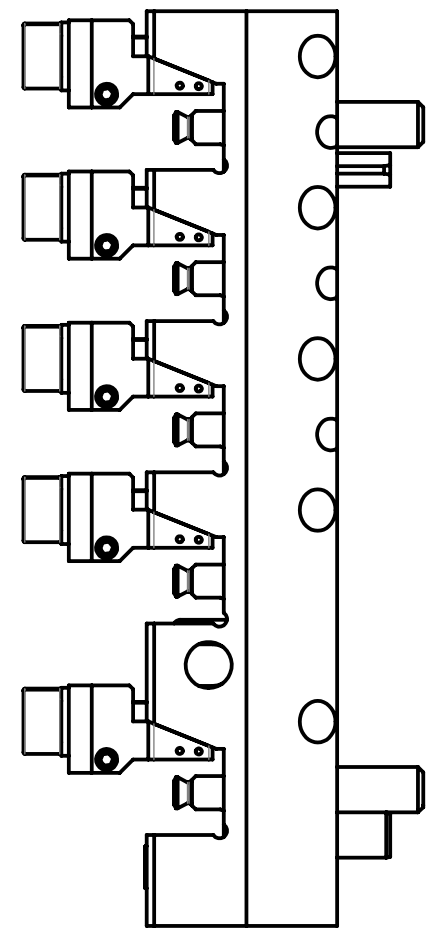

T1-T5 special

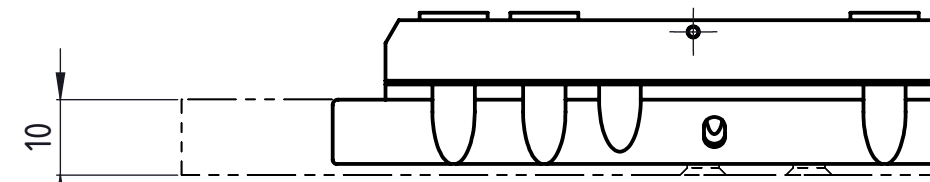
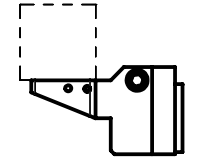
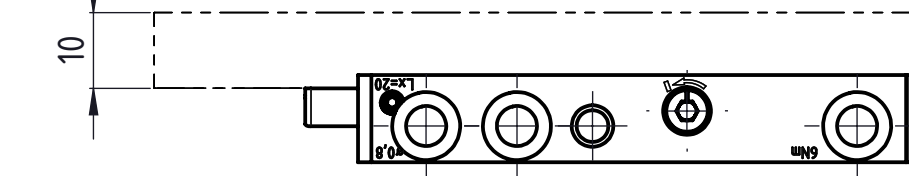

T1-T5 special

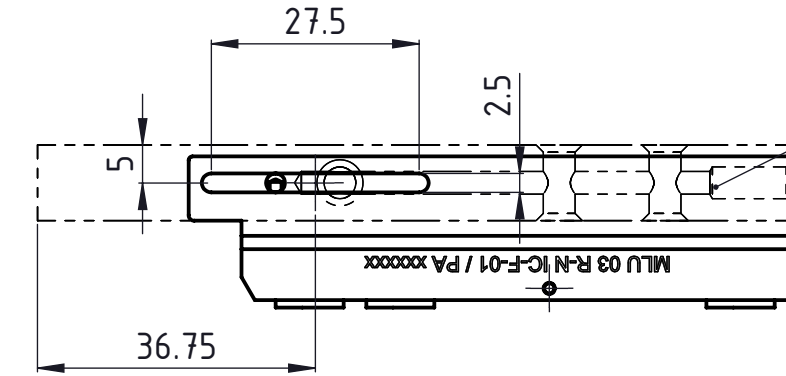
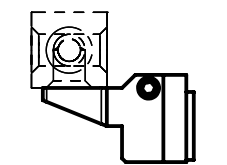
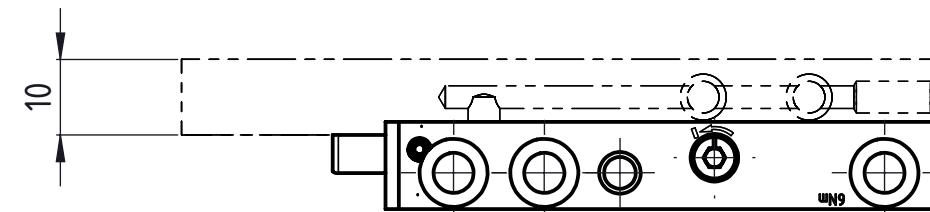

Kühlmittel übergabe an Werkzeug  
 Coolant transfer to tool  
 MLU 03 R-N IC-F-01  
 Artikel Nr. 551442

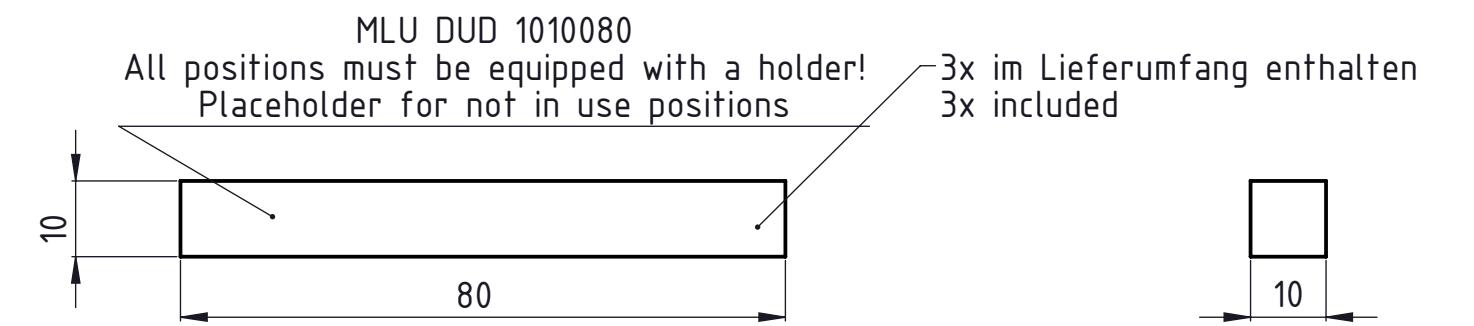

Vorstandlänge des Werkzeuges für optimale Kühlung  
 Longueur d'outil pour un refroidissement optimal  
 Tool length for optimal cooling

Original Spannkeile können verwendet werden  
 Les cales de serrage d'origine peuvent être utilisées  
 Original clamping wedges can be used

Type of machine	Platte ref.	docking systems and sizes (DS)	Tools size
Citizen M16	GTF5210	2xG1/8"	T1-T5 10/10

Beschreibung  
 multidec-LUB Werkzeugplatte komplett

Artikel Bezeichnung  
 MLU CI-01-TPC-IC-5T

Zeichnungsnummer  
 MLU-99-1-2

**UTILIS**  
 Tooling for High Technology

Format A2 Index C