

flow adjustable

front of tool plate

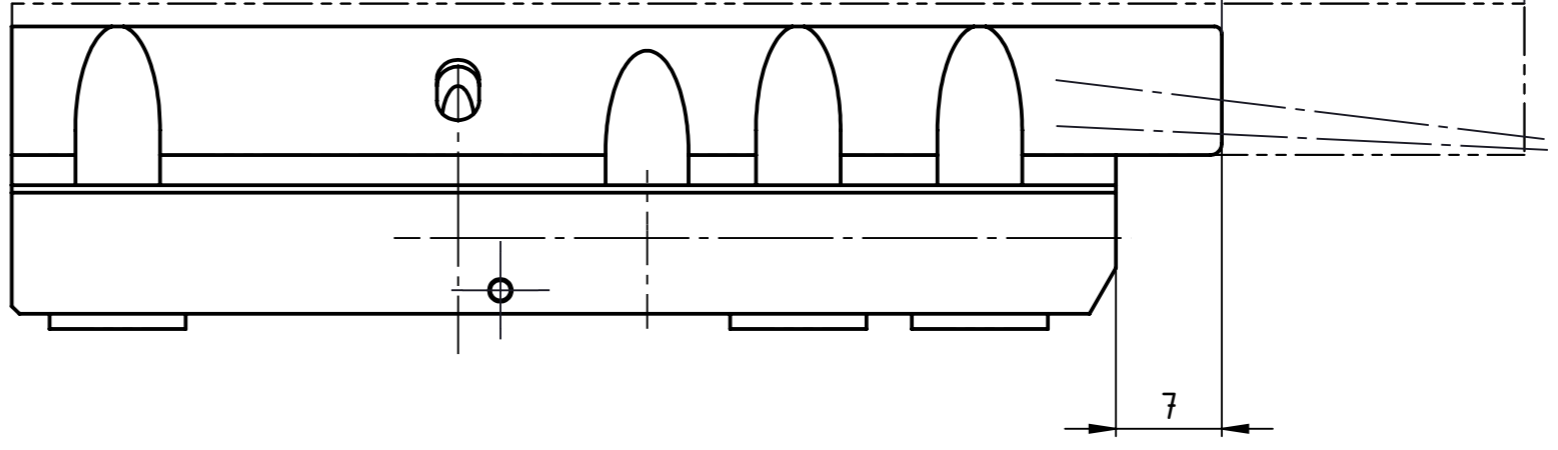
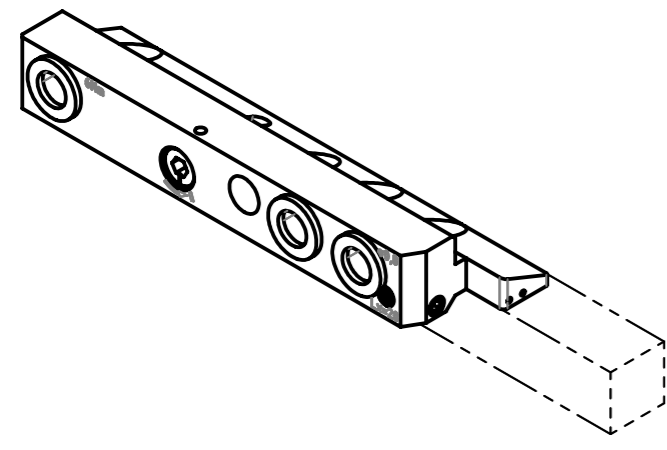

Lx=
 Vorstandlänge des Werkzeuges für optimale Kühlung
 Longueur d'outil pour un refroidissement optimal
 Tool length for optimal cooling

Rechte Ausführung
 Exécution droite
 Right execution

Type of machine	Plate ref.	Tool Size
Citizen M16	GTF5210	10x10